



TECHNICAL GUIDE

ACCLIMATE™ SERIES SPLIT SYSTEM AIR CONDITIONERS 18 SEER – R-410A – 1 PHASE 2 THRU 5 NOMINAL TONS MODELS: AL8B024 THRU 060*



Due to continuous product improvement, specifications are subject to change without notice.

Visit us on the web at

www.upgnet.com and www.luxaire.com

Additional rating information can be found at

www.ahridirectory.org

WARRANTY SUMMARY*

Extended 10-Years limited parts warranty.

Extended Lifetime limited compressor warranty.

Extended parts and compressor warranties require online registration within 90 days of purchase for replacement or closing for new home construction.

*Does not apply to R-22 models, 3-Phase models, or internet sales.

See Limited Warranty certificate in User's Information Manual for details.

DESCRIPTION

The 18 SEER Series unit is the outdoor part of a versatile climate system. It is designed with a matching indoor coil component from. Available for typical applications this climate system is supported with accessories and documents to serve specific functions.

FEATURES

Superior Coil Protection - A stamped, decorative metal coil guard protects the tube-in-fin coil from debris and other damaging material.

Protected Compressor - The compressor is safeguarded against abnormal pressures and temperatures by an internal pressure relief valve, an internal temperature sensor, and factory high and low pressure system controls. A factory installed liquid line filter-drier further protects the compressor against moisture and debris.

Environmentally Friendly Refrigerant - The next generation refrigerant R-410A delivers environmentally friendly performance with zero ozone depletion.

Durable Finish - An automotive quality finish provides the ultimate protection from harmful UV rays and rust creep, ensuring a long-lasting, high quality appearance. A powder-paint topcoat is applied over a baked-on primer using a galvanized, zinc coated steel base material. The result is a finish that has been proven in testing to provide 33% greater durability than conventional powder-coat finishes.

SilentDrive™ System - Features combination of swept-wing fan, composite base pan, isolated compressor compartment, and two-stage compressor to reduce overall sound to a mere whisper.

Low RPM ECM Fan Motor - Helps to reduce airflow noise.

Swept Wing Fan - A fan design boasting technology adapted from aeronautic and defense engineering provides for whisper-quiet operation by allowing air to flow smoothly and efficiently across the fan tips.

Composite Base Pan - The strong and durable composite base pan provides added strength while resisting rust and corrosion, as well as reducing sound and vibration.

Isolated Compressor Compartment - A molded composite bulkhead isolates the refrigeration components and the compressor from the rest of the unit, reducing sound and vibration.

Lower Installed Cost - Designed to provide enhanced installability by featuring a slide-down control compartment that allows easy access to control components, along with angled service valves to reduce overall installation time and cost. Factory charged for a 15 foot lineset.

Factory Installed Filter-Drier - A factory installed, solid core liquid line filter-drier removes harmful debris and moisture from the system.

Easy Service Access - A full end, full service access panel with handle makes for easy entry to internal components.

Communications Capable - Requiring only a simple 4-wire installation, the communicating capability enables the use of the Touch Screen Communicating Control, allowing real time visibility of system operation and the use of diagnostic features, while still maintaining the ability to function with a traditional thermostat.

Premium System Warranty* - Limited lifetime compressor warranty when registered online within 90 days of installation.

Agency Listed - Safety certified by CSA to UL 1995 / CSA 22.2. Performance certified to ANSI/AHRI Standard 210/240 in accordance with the Unitary Small Equipment certification program.

Physical and Electrical Data

MODEL		AL8B024F4C	AL8B036F4C	AL8B048F4C	AL8B060F4C
Unit Supply Voltage		208-230V, 1 ϕ , 60Hz			
Normal Voltage Range ¹		187 to 252			
Minimum Circuit Ampacity		17.4	21.8	29.2	36.6
Max. Overcurrent Device Amps ²		25	35	50	60
Min. Overcurrent Device Amps ³		20	25	30	40
Compressor Amps	Type	2-Stage Scroll	2-Stage Scroll	2-Stage Scroll	2-Stage Scroll
	Rated Load	11.6	15.2	21.1	27.1
	Locked Rotor	58	83	104	153
Crankcase Heater		No	No	No	No
Factory External Discharge Muffler		No	No	No	No
Factory External Check Valve		No	No	No	No
HS Kit Required with TXV ⁴		No	No	No	No
Fan Diameter Inches		24	24	24	24
Fan Motor	Rated HP	1/3	1/3	1/3	1/3
	Rated Load Amps	2.8	2.8	2.8	2.8
	Nominal RPM	685	685	685	685
	Nominal CFM	2900	3000	3260	3220
Coil	Face Area Sq. Ft.	23.6	23.6	23.6	23.6
	Rows Deep	2	2	2	2
	Fins / Inch	16	16	14	14
Liquid Line OD (in) (Field Installed)		3/8	3/8	3/8	3/8
Vapor Line OD (in) (Field Installed)		3/4	3/4	7/8	7/8
Unit Charge (Lbs. - Oz.) ⁵		15 - 4	12 - 14	15 - 14	13 - 10
Charge Per Foot, Oz.		0.62	0.62	0.67	0.67
Operating Weight Lbs.		285	285	310	315

1. Rated in accordance with AHRI Standard 110-2012, utilization range "A".
2. Dual element fuses or HACR circuit breaker. Maximum allowable overcurrent protection.
3. Dual element fuses or HACR circuit breaker. Minimum recommended overcurrent protection.
4. See Hard Start Kit Accessory Installation Manual for Hard Start Kit part number for each model.
5. The Unit Charge is correct for the outdoor unit, smallest matched indoor unit, and 15 feet of refrigerant tubing. For tubing lengths other than 15 feet, add or subtract the amount of refrigerant, using the difference in actual lineset length (not equivalent length) multiplied by the per foot value.

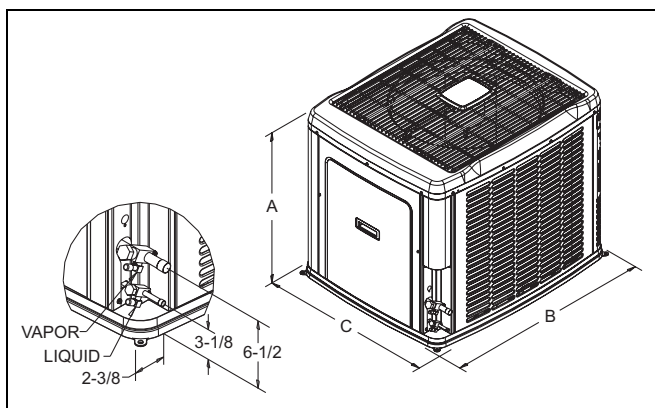

Unit Model	Dimensions (Inches)			Refrigerant Connection Service Valve Size	
	A	B	C	Liquid	Vapor
024	40	42-1/4	34	3/8	3/4
036	40	42-1/4	34		
048	40	42-1/4	34		7/8
060	40	42-1/4	34		

All dimensions are in inches and are subject to change without notice.
 Overall height is from bottom of base pan to top of fan guard.
 Overall length and width include screw heads.

System Charge for Various Matched Systems				
Outdoor Unit	AL8B024F4C	AL8B036F4C	AL8B048F4C	AL8B060F4C
Required TXV ^{1,2}	4F1	4H1	4J1	4K1
Indoor Unit ^{3,4,5}	Additional Charge, Oz			
AHE24B	0	–	–	–
AHE30B	0	–	–	–
AHE36C	–	5	–	–
AHE42D	–	5	–	–
AHE48D	–	–	4	–
AHE60D	–	–	9	5
AHV24B	2	–	–	–
AHV30B	0	–	–	–
AHV36C	6	6	–	–
AHV42D	–	20	–	–
AHV48D	–	14	5	–
AHV60D	–	–	9	5
FC/MC/PC32	0	–	–	–
FC/MC/PC35	0	0	–	–
FC/MC/PC37	5	6	–	–
FC/MC/PC43	5	6	–	–
FC/MC/PC48	14	12	5	–
FC/MC/PC60	–	15	4	0
FC/MC62	–	20	9	5
FC64	–	25	17	12
HD36	5	–	–	–
HD48	–	25	–	–
HD60	–	–	9	4
UC48	9	14	0	–
UC60	–	–	5	1

Some of the combinations shown in the above System Charge table require Advanced Main Air Circulating Fan indoor product. For approved coil only matches, please see the "COOLING CAPACITY - Upflow, Downflow & Horizontal Furnaces and Coils" table.

FOOTNOTES:

1. For applications requiring a TXV use S1-1TVM*** series kit.
2. A TXV kit must be used with these indoor units to obtain system performance.
3. Systems matched with furnaces or air handlers not equipped with blower-off delays may require blower Time Delay Kit S1-2FD06700224.
4. PC coils cannot be used in downflow or horizontal applications. FC coils cannot be used in horizontal applications.
5. Refer to Cooling Performance Data tables for actual performance for specified system matches.

PROCEDURES:

1. Unit factory charge listed on the unit nameplate includes refrigerant for the outdoor unit, the smallest matched indoor unit, and 15 feet of interconnecting line tubing.
2. Verify the TXV and additional charge required for specific matched indoor unit in the system using the above table.
3. Add additional charge for the amount of interconnecting line tubing greater than 15 feet at the rate specified in Physical and Electrical Data Table.
4. For indoor matches requiring additional charge, the refrigerant needs to be weighed in for specific matched indoor unit and actual lineset length.
5. Permanently mark the unit nameplate with the total system charge. Total System Charge = Base Charge (as shipped) + charge adder for matched indoor unit + charge adder for actual lineset length.

COOLING CAPACITY - With Air Handler Coils

UNIT MODEL	AIR HANDLER		COIL MODEL ¹	COOLING					
	MODEL	WIDTH		STAGE	RATED CFM	NET MBH		SEER	EER
						TOTAL	SENS.		
18 SEER AC WITH AIR HANDLERS									
AL8B024F4C	AHE24B	17.5	-	1	515	20.2	13.0	17.25	22.50
				2	795	23.0	16.1		13.50
	AHE30B	17.5	-	1	515	20.2	13.0	17.25	22.50
				2	795	23.0	16.1		13.50
	AHV24B	17.5	-	1	470	19.8	12.4	17.00	22.25
				2	710	22.6	15.3		13.50
	AHV30B	17.5	-	1	500	20.2	13.0	17.50	22.75
				2	775	23.0	16.1		13.50
	AHV36C	21.0	-	1	485	20.2	12.8	17.50	22.75
				2	760	23.2	16.1		13.75
	MV12B	17.5	FC/MC35B	1	620	21.0	14.1	17.50	22.75
				2	800	23.0	16.2		13.75
	MV12B	17.5	FC/MC43B	1	620	21.0	14.2	17.50	22.75
				2	800	23.4	16.6		13.75
	MV12D	24.5	FC/MC48D	1	605	21.2	14.2	18.25	24.00
				2	905	24.0	17.5		14.50
MX12BN21	17.5	FC/MC35B	1	595	20.8	13.7	17.75	23.25	
			2	800	22.8	15.9		13.50	
AL8B036F4C	AHE36C	21.0	-	1	850	29.8	20.1	17.75	23.00
				2	1190	35.2	24.6		13.50
	AHE42D	24.5	-	1	685	28.8	18.3	17.50	22.75
				2	1180	35.4	24.8		14.00
	AHV36C	21.0	-	1	785	29.6	19.4	18.00	23.50
				2	1215	35.0	24.6		13.25
	AHV42D	24.5	-	1	790	29.8	19.6	18.50	24.25
				2	1180	35.4	24.8		13.75
	AHV48D	24.5	-	1	835	30.0	20.1	18.50	24.25
				2	1155	35.2	24.4		14.00
	MV12B	17.5	FC/MC35B	1	775	29.0	18.8	17.00	22.00
				2	1200	34.4	23.8		13.00
	MV12B	17.5	FC/MC43B	1	805	29.6	19.6	17.50	23.00
				2	1225	35.2	24.8		13.50
	MV12D	24.5	FC/MC48D	1	785	29.8	19.5	18.00	23.75
				2	1160	35.4	24.6		14.00
	MV12D	24.5	FC/MC60D	1	735	29.2	18.8	17.75	23.00
				2	1135	35.0	24.0		13.75
	MV12D	24.5	FC/MC62D	1	795	29.8	19.7	18.50	24.25
				2	1235	36.0	25.6		14.25
	MV12D	24.5	FC64D	1	780	30.4	20.1	18.75	24.75
				2	1155	36.5	25.6		14.50
	MV16C	21.0	FC/MC35C	1	780	29.0	18.9	17.25	22.75
				2	1190	34.6	24.0		13.50
	MV16C	21.0	FC/MC43C	1	775	29.2	19.2	17.25	22.50
				2	1200	35.0	24.6		13.50
	MV16C	21.0	FC/MC48C	1	775	29.6	19.5	17.50	23.00
				2	1200	35.2	24.4		13.75
MV20D	24.5	FC/MC48D	1	860	30.2	20.3	18.25	23.75	
			2	1300	36.0	25.8		14.00	
MV20D	24.5	FC/MC60D	1	860	30.2	20.3	18.00	23.75	
			2	1300	36.0	25.6		14.00	
MV20D	24.5	FC/MC62D	1	860	30.0	20.3	18.25	23.75	
			2	1300	36.5	26.2		14.00	

For Notes See Page 5.

COOLING CAPACITY - With Air Handler Coils (Continued)

UNIT MODEL	AIR HANDLER		COIL MODEL ¹	COOLING					
	MODEL	WIDTH		STAGE	RATED CFM	NET MBH		SEER	EER
						TOTAL	SENS.		
18 SEER AC WITH AIR HANDLERS									
AL8B036F4C	MV20D	24.5	FC64D	1	860	31.0	21.1	18.75	24.75
				2	1300	37.0	27.1		14.25
	MX12BN21	17.5	FC/MC35B	1	735	28.8	18.7	17.50	23.00
				2	1125	34.0	23.2		13.00
	MX12BN21	17.5	FC/MC43B	1	740	29.4	19.2	18.00	23.75
				2	1125	34.4	23.6		13.25
	MX12DN21	24.5	FC/MC48D	1	830	30.0	20.1	18.25	24.00
				2	1125	35.2	24.2		14.00
	MX12DN21	24.5	FC/MC60D	1	845	30.0	20.1	18.25	24.00
				2	1150	35.2	24.4		14.00
	MX12DN21	24.5	FC64D	1	880	31.2	21.3	19.00	25.25
				2	1175	36.5	26.0		14.50
AL8B048F4C	AHE48D	24.5	-	1	955	38.5	24.2	16.00	22.00
				2	1600	45.5	31.0		12.75
	AHE60D	24.5	-	1	1160	40.0	26.6	16.50	22.50
				2	1565	46.0	31.6		13.00
	AHV48D	24.5	-	1	1010	39.0	25.0	16.50	22.75
				2	1585	45.5	30.8		12.50
	AHV60D	24.5	-	1	1000	39.0	25.0	16.50	22.50
				2	1570	46.0	31.4		12.50
	MV16C	21.0	FC/MC48C	1	1035	39.5	25.2	16.25	22.00
				2	1625	45.5	31.6		12.50
	MV16C	21.0	FC60C	1	1035	39.0	25.0	16.00	22.00
				2	1625	45.5	31.2		12.50
	MV20D	24.5	FC/MC48D	1	1025	39.5	25.2	16.25	22.25
				2	1620	46.0	31.6		12.75
	MV20D	24.5	FC/MC60D	1	1020	39.0	25.0	15.75	21.50
				2	1600	45.5	31.2		12.50
	MV20D	24.5	FC/MC62D	1	1130	40.0	26.4	17.00	23.25
				2	1715	47.0	33.4		13.00
	MV20D	24.5	FC64D	1	1075	41.0	27.0	17.25	24.00
				2	1630	47.5	33.3		13.00
MX16CN21	21.0	FC/MC48C	1	1015	39.5	25.4	16.75	22.75	
			2	1600	45.5	31.4		12.50	
MX16CN21	21.0	FC60C	1	1020	39.5	25.2	16.50	22.75	
			2	1600	45.5	31.2		12.50	
AL8B060F4C	AHE60D	24.5	-	1	1160	47.5	30.8	15.50	20.75
				2	1835	57.5	40.6		11.75
	AHV60D	24.5	-	1	1090	47.0	30.0	15.50	20.75
				2	1635	56.0	38.7		11.75
	MV20D	24.5	FC/MC60D	1	1160	47.5	30.2	15.50	20.75
				2	1845	57.0	39.7		11.75
	MV20D	24.5	FC/MC62D	1	1260	48.5	32.0	16.00	21.50
				2	1870	58.0	41.2		12.00
	MV20D	24.5	FC64D	1	1160	49.5	31.8	16.25	22.00
				2	1855	58.5	41.6		11.75

Rated in accordance with DOE test procedures (Federal Register 12-27-79 and 3-18-88) and ANSI/AHRI Standard 210/240.
 Cooling MBH based on 80°F entering air temperature, 50% RH (Relative Humidity), and rated air flow.
 EER (Energy Efficiency Ratio) is the total cooling output in BTUs at 95°F (for high stage operation) or 67°F (for low stage operation) outdoor ambient divided by the total electric power in watt-hours at those conditions.
 SEER (Seasonal Energy Efficiency Ratio) is the total cooling output in BTUs during a normal annual usage period for cooling divided by the total electric power input in watt-hours during the same period.

1. MC coils available with a factory installed horizontal drain pan. See price pages for specific model number.
 — = Not applicable.
 MA Modular Air Handlers use Coil Only Ratings.

COOLING CAPACITY - Upflow, Downflow & Horizontal Furnaces and Coils (Coil Only Ratings)

UNIT MODEL	COIL		CFM RANGE (MIN.-MAX.)	COOLING					
	MODEL	WIDTH		STAGE	RATED CFM	NET MBH		SEER ¹	EER
						TOTAL	SENS.		
18 SEER AC COIL ONLY RATINGS									
AL8B024F4C	FC/MC/PC48	21.0,24.5	550 – 650	1	600	20.6	13.7	15.25	19.50
			650 – 950	2	800	23.0	15.9		12.25
AL8B036F4C	FC/MC62	24.5	800 – 1000	1	900	29.4	19.9	15.50	19.50
			1000 – 1400	2	1200	35.0	24.4		12.50
AL8B048F4C	FC/MC62	24.5	1000 – 1400	1	1200	39.5	26.2	14.50	19.25
			1400 – 1800	2	1600	45.5	31.2		12.00
AL8B060F4C	FC/MC62	24.5	1150 – 1550	1	1350	48.5	32.0	14.00	18.50
			1600 – 2000	2	1800	56.5	39.6		11.25

1. Requires a S1-2FD06700224 Blower Time Delay unless a standard furnace is equipped with one.
 MA Modular Air Handlers use Coil Only Ratings.
 PSC furnaces, such as the TG8S, TGLS, and TG9S, use Coil Only Ratings.

COOLING CAPACITY - With High Efficiency Motor Furnaces

UNIT MODEL	FURNACE		COIL MODEL ¹	COOLING					
	MODEL	WIDTH		STAGE	RATED CFM	NET MBH		SEER	EER
						TOTAL	SENS.		
18 SEER AC WITH HIGH EFFICIENCY MOTOR FURNACES²									
AL8B024F4C	T*(8,L)V*A12	14.5	FC/MC/PC32A	1	590	20.6	13.7	17.25	22.50
				2	755	22.8	15.9		13.50
	T*(8,L)V*A12	14.5	FC/MC/PC37A	1	585	20.8	13.6	17.50	22.75
				2	765	23.2	16.3		13.75
	T*(8,L)V*A12	14.5	HD36	1	595	20.2	13.2	17.25	22.00
				2	805	22.6	15.5		13.25
	T*(8,L)V*B12	17.5	FC/MC/PC35B	1	515	20.0	12.9	17.00	21.75
				2	785	23.0	16.0		13.50
	T*(8,L)V*B12	17.5	FC/MC/PC43B	1	515	20.2	13.0	16.75	21.75
				2	790	23.2	16.4		13.75
	T*(8,L)V*B12	17.5	HD36	1	515	19.5	12.4	16.75	21.25
				2	760	22.4	15.1		13.25
	T*(8,L)V*C16	21.0	FC/MC/PC35C	1	600	20.6	13.7	17.25	22.50
				2	775	23.0	16.0		13.75
	T*(8,L)V*C16	21.0	FC/MC/PC43C	1	645	21.4	14.6	17.75	23.25
				2	770	23.2	16.2		14.00
	T*(8,L)V*C16	21.0	HD36	1	595	20.2	13.3	17.25	22.50
				2	855	22.8	15.6		13.50
	T*9V*A10	14.5	FC/MC/PC32A	1	580	20.6	13.6	16.75	21.75
				2	785	22.6	15.8		12.75
	T*9V*A10	14.5	FC/MC/PC37A	1	570	20.6	13.6	16.75	21.75
				2	790	23.0	16.1		13.00
	T*9V*B12	17.5	FC/MC/PC35B	1	550	20.4	13.4	17.25	22.50
				2	815	23.0	16.2		13.50
	T*9V*B12	17.5	FC/MC/PC43B	1	550	20.8	13.7	17.75	23.25
				2	800	23.2	16.3		13.50
	T*9V*B12	17.5	HD36	1	590	20.2	13.2	17.25	22.00
				2	815	22.8	15.5		13.50
T*9V*C16	21.0	FC/MC/PC35C	1	645	21.2	14.5	17.75	23.25	
			2	900	23.4	17.1		13.50	
T*9V*C16	21.0	FC/MC/PC48C	1	635	21.4	14.5	18.25	24.00	
			2	890	23.8	17.5		14.00	

For Notes See Page 28.

COOLING CAPACITY - With High Efficiency Motor Furnaces (Continued)

UNIT MODEL	FURNACE		COIL MODEL ¹	COOLING					
	MODEL	WIDTH		STAGE	RATED CFM	NET MBH		SEER	EER
						TOTAL	SENS.		
18 SEER AC WITH HIGH EFFICIENCY MOTOR FURNACES²									
AL8B024F4C	T*9V*C16	21.0	UC48C	1	635	21.0	14.4	17.50	23.25
				2	890	23.4	17.2		13.75
	T*9V*C20	21.0	FC/MC/PC43C	1	630	21.2	14.5	18.00	23.75
				2	890	23.8	17.4		14.00
	T*9V*C20	21.0	FC/MC/PC48C	1	630	21.4	14.5	18.25	24.00
				2	890	23.8	17.5		14.00
	T*9V*C20	21.0	UC48C	1	630	21.0	14.2	17.50	23.25
				2	890	23.4	17.2		13.75
	TM8X060A12MP11	14.5	HD36	1	605	20.2	13.2	16.75	21.50
				2	815	22.8	15.6		13.50
	TM8X080B12MP11	17.5	HD36	1	655	20.6	13.7	18.00	23.25
				2	855	23.2	16.1		14.00
	TM8X080C16MP11	21.0	FC/MC/PC35C	1	635	21.0	14.3	17.25	22.50
				2	800	22.8	16.0		13.00
	TM8X080C16MP11	21.0	FC/MC/PC43C	1	630	21.2	14.3	17.50	22.75
				2	800	23.0	16.3		13.00
	TM8X080C16MP11	21.0	FC/MC/PC48C	1	630	21.2	14.4	17.75	23.00
				2	800	23.2	16.2		13.25
	TM8X080C16MP11	21.0	HD36	1	695	20.8	14.2	17.75	23.25
				2	855	23.2	16.1		14.00
	TM8X080C16MP11	21.0	UC48C	1	630	21.0	14.1	17.00	22.50
				2	800	22.8	16.0		13.00
	TM8X100C16MP11	21.0	FC/MC/PC35C	1	635	21.0	14.3	17.25	22.50
				2	800	22.8	16.0		13.00
	TM8X100C16MP11	21.0	FC/MC/PC43C	1	630	21.2	14.3	17.50	22.75
				2	800	23.0	16.3		13.00
	TM8X100C16MP11	21.0	FC/MC/PC48C	1	630	21.2	14.4	17.75	23.00
				2	800	23.2	16.2		13.25
	TM8X100C16MP11	21.0	HD36	1	695	20.8	14.2	17.75	23.25
				2	855	23.2	16.1		14.00
	TM8X100C16MP11	21.0	UC48C	1	630	21.0	14.1	17.00	22.50
				2	800	22.8	16.0		13.00
	TMLX060A12MP11	14.5	HD36	1	605	20.2	13.2	16.75	21.50
				2	815	22.8	15.6		13.50
	TMLX080B12MP11	17.5	HD36	1	655	20.6	13.7	18.00	23.25
				2	855	23.2	16.1		14.00
	TMLX080C16MP11	21.0	FC/MC/PC35C	1	635	21.0	14.3	17.25	22.50
				2	800	22.8	16.0		13.00
	TMLX080C16MP11	21.0	FC/MC/PC43C	1	630	21.2	14.3	17.50	22.75
				2	800	23.0	16.3		13.00
TMLX080C16MP11	21.0	FC/MC/PC48C	1	630	21.2	14.4	17.75	23.00	
			2	800	23.2	16.2		13.25	
TMLX080C16MP11	21.0	HD36	1	695	20.8	14.2	17.75	23.25	
			2	855	23.2	16.1		14.00	
TMLX080C16MP11	21.0	UC48C	1	630	21.0	14.1	17.00	22.50	
			2	800	22.8	16.0		13.00	
TMLX100C16MP11	21.0	FC/MC/PC35C	1	635	21.0	14.3	17.25	22.50	
			2	800	22.8	16.0		13.00	
TMLX100C16MP11	21.0	FC/MC/PC43C	1	630	21.2	14.3	17.50	22.75	
			2	800	23.0	16.3		13.00	
TMLX100C16MP11	21.0	FC/MC/PC48C	1	630	21.2	14.4	17.75	23.00	
			2	800	23.2	16.2		13.25	

For Notes See Page 28.

COOLING CAPACITY - With High Efficiency Motor Furnaces (Continued)

UNIT MODEL	FURNACE		COIL MODEL ¹	COOLING					
	MODEL	WIDTH		STAGE	RATED CFM	NET MBH		SEER	EER
						TOTAL	SENS.		
18 SEER AC WITH HIGH EFFICIENCY MOTOR FURNACES²									
AL8B024F4C	TMLX100C16MP11	21.0	HD36	1	695	20.8	14.2	17.75	23.25
				2	855	23.2	16.1		14.00
	TMLX100C16MP11	21.0	UC48C	1	630	21.0	14.1	17.00	22.50
				2	800	22.8	16.0		13.00
	TM9E040A10MP11	14.5	FC/MC/PC32A	1	565	20.6	13.7	17.25	22.25
				2	775	22.4	15.7		12.50
	TM9E060B12MP11	17.5	HD36	1	625	20.2	13.3	17.50	22.75
				2	790	22.8	15.6		13.75
	TM9E080B12MP11	17.5	HD36	1	625	20.2	13.3	17.50	22.75
				2	790	22.8	15.6		13.75
	TM9E080C16MP11	21.0	HD36	1	690	20.8	14.1	17.75	23.00
				2	730	22.4	15.0		13.75
	TM9E100C16MP11	21.0	HD36	1	690	20.8	14.1	17.75	23.00
				2	730	22.4	15.0		13.75
	TM9E100C20MP11	21.0	HD36	1	795	21.2	15.3	17.75	22.75
				2	850	23.0	15.8		13.75
	TM9X040A10MP11	14.5	FC/MC/PC32A	1	565	20.6	13.7	17.25	22.25
				2	775	22.4	15.7		12.50
	TM9X060B12MP11	17.5	HD36	1	625	20.2	13.3	17.50	22.75
				2	790	22.8	15.6		13.75
	TM9X080B12MP11	17.5	HD36	1	625	20.2	13.3	17.50	22.75
				2	790	22.8	15.6		13.75
	TM9X080C16MP11	21.0	HD36	1	690	20.8	14.1	17.75	23.00
				2	730	22.4	15.0		13.75
	TM9X100C16MP11	21.0	HD36	1	690	20.8	14.1	17.75	23.00
				2	730	22.4	15.0		13.75
	TM9X100C20MP11	21.0	HD36	1	795	21.2	15.3	17.75	22.75
				2	850	23.0	15.8		13.75
	L*LC*A12	14.5	FC/MC/PC32A	1	590	20.6	13.7	17.25	22.50
				2	755	22.8	15.9		13.50
	L*LC*A12	14.5	FC/MC/PC37A	1	585	20.8	13.6	17.50	22.75
				2	765	23.2	16.3		13.75
	L*LC*A12	14.5	HD36	1	595	20.2	13.2	17.25	22.00
				2	805	22.6	15.5		13.25
	L*LC*B12	17.5	FC/MC/PC35B	1	515	20.0	12.9	17.00	21.75
				2	785	23.0	16.0		13.50
L*LC*B12	17.5	FC/MC/PC43B	1	515	20.2	13.0	16.75	21.75	
			2	790	23.2	16.4		13.75	
L*LC*B12	17.5	HD36	1	515	19.5	12.4	16.75	21.25	
			2	760	22.4	15.1		13.25	
L*LC*C16	21.0	FC/MC/PC35C	1	600	20.6	13.7	17.25	22.50	
			2	775	23.0	16.0		13.75	
L*LC*C16	21.0	FC/MC/PC43C	1	645	21.4	14.6	17.75	23.25	
			2	770	23.2	16.2		14.00	
L*LC*C16	21.0	HD36	1	595	20.2	13.3	17.25	22.50	
			2	855	22.8	15.6		13.50	
L*9C*B12	17.5	FC/MC/PC35B	1	550	20.4	13.4	17.25	22.50	
			2	815	23.0	16.2		13.50	
L*9C*B12	17.5	FC/MC/PC43B	1	550	20.8	13.7	17.75	23.25	
			2	800	23.2	16.3		13.50	

For Notes See Page 28.

COOLING CAPACITY - With High Efficiency Motor Furnaces (Continued)

UNIT MODEL	FURNACE		COIL MODEL ¹	COOLING					
	MODEL	WIDTH		STAGE	RATED CFM	NET MBH		SEER	EER
						TOTAL	SENS.		
18 SEER AC WITH HIGH EFFICIENCY MOTOR FURNACES²									
AL8B024F4C	L*9C*B12	17.5	HD36	1	590	20.2	13.2	17.25	22.00
				2	815	22.8	15.5		13.50
	L*9C*C16	21.0	FC/MC/PC35C	1	645	21.2	14.5	17.75	23.25
				2	900	23.4	17.1		13.50
	L*9C*C16	21.0	FC/MC/PC48C	1	635	21.4	14.5	18.25	24.00
				2	890	23.8	17.5		14.00
	L*9C*C16	21.0	UC48C	1	635	21.0	14.4	17.50	23.25
				2	890	23.4	17.2		13.75
	L*9C*C20	21.0	FC/MC/PC43C	1	630	21.2	14.5	18.00	23.75
				2	890	23.8	17.4		14.00
	L*9C*C20	21.0	FC/MC/PC48C	1	630	21.4	14.5	18.25	24.00
				2	890	23.8	17.5		14.00
	L*9C*C20	21.0	UC48C	1	630	21.0	14.2	17.50	23.25
				2	890	23.4	17.2		13.75
AL8B036F4C	T*(8,L)V*A12	14.5	FC/MC/PC37A	1	730	28.8	18.5	16.75	21.50
				2	1150	34.4	23.6		12.75
	T*(8,L)V*B12	17.5	FC/MC/PC35B	1	775	28.8	18.7	16.75	21.75
				2	1150	34.2	23.6		12.75
	T*(8,L)V*B12	17.5	FC/MC/PC43B	1	860	29.8	20.1	17.00	22.00
				2	1275	35.0	24.8		12.50
	T*(8,L)V*B12	17.5	HD48	1	750	29.2	18.8	17.50	22.75
				2	1210	35.4	24.4		13.25
	T*(8,L)V*C16	21.0	FC/MC/PC35C	1	770	29.0	18.8	17.00	22.00
				2	1210	34.4	23.8		13.00
	T*(8,L)V*C16	21.0	FC/MC/PC43C	1	770	29.2	19.1	17.25	22.50
				2	1190	35.0	24.4		13.50
	T*(8,L)V*C16	21.0	FC/MC/PC48C	1	725	29.2	18.7	17.25	22.50
				2	1195	35.4	24.6		13.75
	T*(8,L)V*C16	21.0	FC/PC60C	1	710	29.2	18.8	17.25	22.50
				2	1185	35.0	24.0		13.75
	T*(8,L)V*C16	21.0	HD48	1	810	29.8	19.5	18.00	23.25
				2	1210	35.8	24.6		13.75
	T*(8,L)V*C16	21.0	UC48C	1	810	28.8	19.1	17.00	22.25
				2	1210	34.8	24.0		13.50
	T*(8,L)V*C16	21.0	UC60C	1	810	29.4	19.3	17.50	23.00
				2	1195	35.0	24.4		13.50
	T*(8,L)V*C20	21.0	FC/MC/PC35C	1	1020	30.2	21.3	17.25	22.50
				2	1165	34.2	23.6		13.00
	T*(8,L)V*C20	21.0	FC/MC/PC43C	1	740	29.0	18.8	17.25	22.50
				2	1190	35.0	24.4		13.50
	T*(8,L)V*C20	21.0	FC/MC/PC48C	1	715	29.0	18.6	17.50	22.75
				2	1150	35.2	24.2		13.75
T*(8,L)V*C20	21.0	FC/PC60C	1	800	29.6	19.5	17.75	23.25	
			2	1215	35.4	24.8		13.75	
T*(8,L)V*C20	21.0	HD48	1	720	29.0	18.5	17.75	23.00	
			2	1155	35.4	24.2		13.75	
T*(8,L)V*C20	21.0	UC48C	1	720	28.0	18.2	16.75	21.75	
			2	1155	34.0	23.2		13.25	
T*(8,L)V*C20	21.0	UC60C	1	800	29.4	19.3	17.50	23.00	
			2	1215	35.0	24.4		13.50	
T*9V*B12	17.5	FC/MC/PC35B	1	810	28.8	18.7	16.50	21.50	
			2	1190	34.2	23.6		12.50	

For Notes See Page 28.

COOLING CAPACITY - With High Efficiency Motor Furnaces (Continued)

UNIT MODEL	FURNACE		COIL MODEL ¹	COOLING					
	MODEL	WIDTH		STAGE	RATED CFM	NET MBH		SEER	EER
						TOTAL	SENS.		
18 SEER AC WITH HIGH EFFICIENCY MOTOR FURNACES²									
AL8B036F4C	T*9V*B12	17.5	FC/MC/PC43B	1	815	29.6	19.7	17.00	22.25
				2	1200	34.6	24.2		12.75
	T*9V*B12	17.5	HD48	1	710	28.8	18.3	17.25	22.25
				2	1150	35.0	23.6		13.00
	T*9V*C16	21.0	FC/MC/PC35C	1	790	29.0	18.8	17.00	22.25
				2	1215	34.4	23.6		13.00
	T*9V*C16	21.0	FC/MC/PC43C	1	815	29.6	19.7	17.25	22.50
				2	1240	35.0	24.8		13.00
	T*9V*C16	21.0	FC/MC/PC48C	1	780	29.6	19.5	17.50	23.00
				2	1195	35.0	24.4		13.25
	T*9V*C16	21.0	FC/PC60C	1	810	29.6	19.6	17.50	22.75
				2	1235	35.2	24.8		13.25
	T*9V*C16	21.0	HD48	1	780	29.4	19.1	17.75	23.00
				2	1195	35.2	24.4		13.25
	T*9V*C16	21.0	UC48C	1	780	28.4	18.5	16.75	21.75
				2	1195	33.8	23.0		13.00
	T*9V*C16	21.0	UC60C	1	810	29.4	19.5	17.25	22.50
				2	1235	35.2	24.6		13.25
	T*9V*C20	21.0	FC/MC/PC35C	1	760	28.8	18.8	17.00	22.00
				2	1330	34.8	24.8		12.75
	T*9V*C20	21.0	FC/MC/PC43C	1	780	29.4	19.3	17.50	22.75
				2	1200	35.0	24.4		13.25
	T*9V*C20	21.0	FC/MC/PC48C	1	745	29.2	18.9	17.50	22.75
				2	1330	35.8	25.8		13.25
	T*9V*C20	21.0	FC/PC60C	1	770	29.4	19.2	17.50	23.00
				2	1330	35.6	25.6		13.25
	T*9V*C20	21.0	HD48	1	745	29.2	18.8	17.50	22.75
				2	1330	36.0	25.4		13.25
	T*9V*C20	21.0	UC48C	1	755	28.4	18.4	16.50	21.75
				2	1330	34.4	24.9		12.75
	T*9V*C20	21.0	UC60C	1	770	29.2	19.1	17.50	22.75
				2	1330	35.6	25.6		13.25
	T*9V*D20	24.5	FC/MC/PC48D	1	830	30.0	19.9	17.75	23.25
				2	1240	35.6	25.2		13.50
	T*9V*D20	24.5	FC/MC/PC60D	1	830	29.8	19.9	17.75	23.25
				2	1225	35.4	24.8		13.50
	T*9V*D20	24.5	FC/MC62D	1	835	30.0	20.1	18.00	23.25
				2	1235	35.8	25.4		13.75
	T*9V*D20	24.5	FC64D	1	835	30.6	20.7	18.50	24.25
				2	1235	37.0	26.4		14.00
T*9V*D20	24.5	HD48	1	830	29.8	19.7	17.75	23.25	
			2	1225	35.8	24.6		13.75	
T*9V*D20	24.5	UC48D	1	830	29.0	19.4	17.00	22.25	
			2	1240	34.4	24.0		13.25	
T*9V*D20	24.5	UC60D	1	830	29.6	19.7	17.50	23.00	
			2	1225	35.2	24.8		13.50	
TM8X060A12MP11	14.5	FC/MC/PC37A	1	770	29.4	19.1	17.50	22.75	
			2	1125	34.2	23.4		12.75	
TM8X080B12MP11	17.5	FC/MC/PC35B	1	790	29.0	18.8	17.00	22.25	
			2	1150	34.2	23.6		12.75	

For Notes See Page 28.

COOLING CAPACITY - With High Efficiency Motor Furnaces (Continued)

UNIT MODEL	FURNACE		COIL MODEL ¹	COOLING					
	MODEL	WIDTH		STAGE	RATED CFM	NET MBH		SEER	EER
						TOTAL	SENS.		
18 SEER AC WITH HIGH EFFICIENCY MOTOR FURNACES²									
AL8B036F4C	TM8X080B12MP11	17.5	FC/MC/PC43B	1	805	29.4	19.1	17.25	22.75
				2	1175	34.2	23.4		12.75
	TM8X080B12MP11	17.5	HD48	1	825	30.0	19.8	18.25	24.00
				2	1150	35.4	24.2		13.75
	TM8X080C16MP11	21.0	FC/MC/PC35C	1	765	29.0	19.0	17.50	23.00
				2	1125	34.2	23.2		13.25
	TM8X080C16MP11	21.0	FC/MC/PC43C	1	775	29.4	19.2	18.00	23.50
				2	1150	34.4	23.6		13.25
	TM8X080C16MP11	21.0	FC/MC/PC48C	1	775	29.8	19.5	18.25	24.00
				2	1150	35.2	24.4		13.50
	TM8X080C16MP11	21.0	FC/MC/PC48D	1	805	29.8	19.5	18.00	23.75
				2	1175	35.2	24.4		13.50
	TM8X080C16MP11	21.0	FC/MC/PC60D	1	800	29.8	19.7	18.25	24.00
				2	1175	35.2	24.4		13.50
	TM8X080C16MP11	21.0	FC/MC62D	1	785	29.6	19.6	18.25	23.75
				2	1175	35.6	24.8		13.75
	TM8X080C16MP11	21.0	FC/PC60C	1	790	29.6	19.5	18.00	23.75
				2	1175	35.2	24.4		13.50
	TM8X080C16MP11	21.0	FC64D	1	795	30.4	20.1	18.75	24.75
				2	1175	36.5	25.6		14.00
	TM8X080C16MP11	21.0	HD48	1	650	28.4	17.8	17.50	22.75
				2	1120	35.4	24.0		14.00
	TM8X080C16MP11	21.0	UC48C	1	775	28.6	18.6	17.25	22.50
				2	1150	34.0	23.2		13.25
	TM8X080C16MP11	21.0	UC48D	1	805	28.6	18.6	17.25	22.50
				2	1175	34.0	23.2		13.25
	TM8X080C16MP11	21.0	UC60C	1	790	29.4	19.4	18.00	23.50
				2	1175	35.0	24.4		13.50
	TM8X080C16MP11	21.0	UC60D	1	800	29.4	19.4	18.00	23.50
				2	1175	35.0	24.4		13.50
	TM8X100C16MP11	21.0	FC/MC/PC35C	1	765	29.0	19.0	17.50	23.00
				2	1125	34.2	23.2		13.25
	TM8X100C16MP11	21.0	FC/MC/PC43C	1	775	29.4	19.2	18.00	23.50
				2	1150	34.4	23.6		13.25
	TM8X100C16MP11	21.0	FC/MC/PC48C	1	775	29.8	19.5	18.25	24.00
				2	1150	35.2	24.4		13.50
	TM8X100C16MP11	21.0	FC/MC/PC48D	1	805	29.8	19.5	18.00	23.75
				2	1175	35.2	24.4		13.50
	TM8X100C16MP11	21.0	FC/MC/PC60D	1	800	29.8	19.7	18.25	24.00
				2	1175	35.2	24.4		13.50
TM8X100C16MP11	21.0	FC/MC62D	1	785	29.6	19.6	18.25	23.75	
			2	1175	35.6	24.8		13.75	
TM8X100C16MP11	21.0	FC/PC60C	1	790	29.6	19.5	18.00	23.75	
			2	1175	35.2	24.4		13.50	
TM8X100C16MP11	21.0	FC64D	1	795	30.4	20.1	18.75	24.75	
			2	1175	36.5	25.6		14.00	
TM8X100C16MP11	21.0	HD48	1	650	28.4	17.8	17.50	22.75	
			2	1120	35.4	24.0		14.00	
TM8X100C16MP11	21.0	UC48C	1	775	28.6	18.6	17.25	22.50	
			2	1150	34.0	23.2		13.25	
TM8X100C16MP11	21.0	UC48D	1	805	28.6	18.6	17.25	22.50	
			2	1175	34.0	23.2		13.25	

For Notes See Page 28.

COOLING CAPACITY - With High Efficiency Motor Furnaces (Continued)

UNIT MODEL	FURNACE		COIL MODEL ¹	COOLING					
	MODEL	WIDTH		STAGE	RATED CFM	NET MBH		SEER	EER
						TOTAL	SENS.		
18 SEER AC WITH HIGH EFFICIENCY MOTOR FURNACES²									
AL8B036F4C	TM8X100C16MP11	21.0	UC60C	1	790	29.4	19.4	18.00	23.50
				2	1175	35.0	24.4		13.50
	TM8X100C16MP11	21.0	UC60D	1	800	29.4	19.4	18.00	23.50
				2	1175	35.0	24.4		13.50
	TM8X100C20MP11	21.0	HD48	1	820	30.0	19.7	18.00	23.75
				2	1245	36.0	25.0		14.00
	TM8X120C20MP11	21.0	HD48	1	820	30.0	19.7	18.00	23.75
				2	1245	36.0	25.0		14.00
	TMLX060A12MP11	14.5	FC/MC/PC37A	1	770	29.4	19.1	17.50	22.75
				2	1125	34.2	23.4		12.75
	TMLX080B12MP11	17.5	FC/MC/PC35B	1	790	29.0	18.8	17.00	22.25
				2	1150	34.2	23.6		12.75
	TMLX080B12MP11	17.5	FC/MC/PC43B	1	805	29.4	19.1	17.25	22.75
				2	1175	34.2	23.4		12.75
	TMLX080B12MP11	17.5	HD48	1	825	30.0	19.8	18.25	24.00
				2	1150	35.4	24.2		13.75
	TMLX080C16MP11	21.0	FC/MC/PC35C	1	765	29.0	19.0	17.50	23.00
				2	1125	34.2	23.2		13.25
	TMLX080C16MP11	21.0	FC/MC/PC43C	1	775	29.4	19.2	18.00	23.50
				2	1150	34.4	23.6		13.25
	TMLX080C16MP11	21.0	FC/MC/PC48C	1	775	29.8	19.5	18.25	24.00
				2	1150	35.2	24.4		13.50
	TMLX080C16MP11	21.0	FC/MC/PC48D	1	805	29.8	19.5	18.00	23.75
				2	1175	35.2	24.4		13.50
	TMLX080C16MP11	21.0	FC/MC/PC60D	1	800	29.8	19.7	18.25	24.00
				2	1175	35.2	24.4		13.50
	TMLX080C16MP11	21.0	FC/MC62D	1	785	29.6	19.6	18.25	23.75
				2	1175	35.6	24.8		13.75
	TMLX080C16MP11	21.0	FC/PC60C	1	790	29.6	19.5	18.00	23.75
				2	1175	35.2	24.4		13.50
	TMLX080C16MP11	21.0	FC64D	1	795	30.4	20.1	18.75	24.75
				2	1175	36.5	25.6		14.00
	TMLX080C16MP11	21.0	HD48	1	650	28.4	17.8	17.50	22.75
				2	1120	35.4	24.0		14.00
	TMLX080C16MP11	21.0	UC48C	1	775	28.6	18.6	17.25	22.50
				2	1150	34.0	23.2		13.25
TMLX080C16MP11	21.0	UC48D	1	805	28.6	18.6	17.25	22.50	
			2	1175	34.0	23.2		13.25	
TMLX080C16MP11	21.0	UC60C	1	790	29.4	19.4	18.00	23.50	
			2	1175	35.0	24.4		13.50	
TMLX080C16MP11	21.0	UC60D	1	800	29.4	19.4	18.00	23.50	
			2	1175	35.0	24.4		13.50	
TMLX100C16MP11	21.0	FC/MC/PC35C	1	765	29.0	19.0	17.50	23.00	
			2	1125	34.2	23.2		13.25	
TMLX100C16MP11	21.0	FC/MC/PC43C	1	775	29.4	19.2	18.00	23.50	
			2	1150	34.4	23.6		13.25	
TMLX100C16MP11	21.0	FC/MC/PC48C	1	775	29.8	19.5	18.25	24.00	
			2	1150	35.2	24.4		13.50	
TMLX100C16MP11	21.0	FC/MC/PC48D	1	805	29.8	19.5	18.00	23.75	
			2	1175	35.2	24.4		13.50	

For Notes See Page 28.

COOLING CAPACITY - With High Efficiency Motor Furnaces (Continued)

UNIT MODEL	FURNACE		COIL MODEL ¹	COOLING					
	MODEL	WIDTH		STAGE	RATED CFM	NET MBH		SEER	EER
						TOTAL	SENS.		
18 SEER AC WITH HIGH EFFICIENCY MOTOR FURNACES²									
AL8B036F4C	TMLX100C16MP11	21.0	FC/MC/PC60D	1	800	29.8	19.7	18.25	24.00
				2	1175	35.2	24.4		13.50
	TMLX100C16MP11	21.0	FC/MC62D	1	785	29.6	19.6	18.25	23.75
				2	1175	35.6	24.8		13.75
	TMLX100C16MP11	21.0	FC/PC60C	1	790	29.6	19.5	18.00	23.75
				2	1175	35.2	24.4		13.50
	TMLX100C16MP11	21.0	FC64D	1	795	30.4	20.1	18.75	24.75
				2	1175	36.5	25.6		14.00
	TMLX100C16MP11	21.0	HD48	1	650	28.4	17.8	17.50	22.75
				2	1120	35.4	24.0		14.00
	TMLX100C16MP11	21.0	UC48C	1	775	28.6	18.6	17.25	22.50
				2	1150	34.0	23.2		13.25
	TMLX100C16MP11	21.0	UC48D	1	805	28.6	18.6	17.25	22.50
				2	1175	34.0	23.2		13.25
	TMLX100C16MP11	21.0	UC60C	1	790	29.4	19.4	18.00	23.50
				2	1175	35.0	24.4		13.50
	TMLX100C16MP11	21.0	UC60D	1	800	29.4	19.4	18.00	23.50
				2	1175	35.0	24.4		13.50
	TMLX100C20MP11	21.0	HD48	1	820	30.0	19.7	18.00	23.75
				2	1245	36.0	25.0		14.00
	TMLX120C20MP11	21.0	HD48	1	820	30.0	19.7	18.00	23.75
				2	1245	36.0	25.0		14.00
	TM9E060B12MP11	17.5	FC/MC/PC35B	1	730	28.6	18.5	17.00	22.25
				2	1125	33.8	23.0		12.50
	TM9E060B12MP11	17.5	FC/MC/PC43B	1	730	29.0	18.7	17.25	22.75
				2	1125	34.2	23.4		12.75
	TM9E060B12MP11	17.5	HD48	1	760	29.4	18.9	17.75	23.25
				2	1290	35.8	25.4		13.50
	TM9E080B12MP11	17.5	FC/MC/PC35B	1	730	28.6	18.5	17.00	22.25
				2	1125	33.8	23.0		12.50
	TM9E080B12MP11	17.5	FC/MC/PC43B	1	730	29.0	18.7	17.25	22.75
				2	1125	34.2	23.4		12.75
TM9E080B12MP11	17.5	HD48	1	760	29.4	18.9	17.75	23.25	
			2	1290	35.8	25.4		13.50	
TM9E080C16MP11	21.0	FC/MC/PC48D	1	775	29.6	19.5	18.00	23.50	
			2	1175	35.0	24.4		13.25	
TM9E080C16MP11	21.0	FC/MC62D	1	765	29.2	19.1	18.00	23.25	
			2	1175	35.4	24.6		13.50	
TM9E080C16MP11	21.0	FC64D	1	775	30.4	20.1	18.50	24.50	
			2	1175	36.5	25.4		13.75	
TM9E080C16MP11	21.0	HD48	1	675	28.6	18.0	17.50	23.00	
			2	1320	36.0	25.8		13.75	
TM9E080C16MP11	21.0	UC48D	1	775	28.6	18.6	17.00	22.25	
			2	1175	33.8	23.0		13.00	
TM9E100C16MP11	21.0	FC/MC/PC48D	1	775	29.6	19.5	18.00	23.50	
			2	1175	35.0	24.4		13.25	
TM9E100C16MP11	21.0	FC/MC62D	1	765	29.2	19.1	18.00	23.25	
			2	1175	35.4	24.6		13.50	
TM9E100C16MP11	21.0	FC64D	1	775	30.4	20.1	18.50	24.50	
			2	1175	36.5	25.4		13.75	
TM9E100C16MP11	21.0	HD48	1	675	28.6	18.0	17.50	23.00	
			2	1320	36.0	25.8		13.75	

For Notes See Page 28.

COOLING CAPACITY - With High Efficiency Motor Furnaces (Continued)

UNIT MODEL	FURNACE		COIL MODEL ¹	COOLING					
	MODEL	WIDTH		STAGE	RATED CFM	NET MBH		SEER	EER
						TOTAL	SENS.		
18 SEER AC WITH HIGH EFFICIENCY MOTOR FURNACES²									
AL8B036F4C	TM9E100C16MP11	21.0	UC48D	1	775	28.6	18.6	17.00	22.25
				2	1175	33.8	23.0		13.00
	TM9E100C20MP11	21.0	HD48	1	810	29.8	19.5	18.00	23.50
				2	1245	36.0	25.0		14.00
	TM9E120D20MP11	24.5	HD48	1	830	29.8	19.8	18.25	23.75
				2	1260	36.0	25.2		14.00
	TM9X060B12MP11	17.5	FC/MC/PC35B	1	730	28.6	18.5	17.00	22.25
				2	1125	33.8	23.0		12.50
	TM9X060B12MP11	17.5	FC/MC/PC43B	1	730	29.0	18.7	17.25	22.75
				2	1125	34.2	23.4		12.75
	TM9X060B12MP11	17.5	HD48	1	760	29.4	18.9	17.75	23.25
				2	1290	35.8	25.4		13.50
	TM9X080B12MP11	17.5	FC/MC/PC35B	1	730	28.6	18.5	17.00	22.25
				2	1125	33.8	23.0		12.50
	TM9X080B12MP11	17.5	FC/MC/PC43B	1	730	29.0	18.7	17.25	22.75
				2	1125	34.2	23.4		12.75
	TM9X080B12MP11	17.5	HD48	1	760	29.4	18.9	17.75	23.25
				2	1290	35.8	25.4		13.50
	TM9X080C16MP11	21.0	FC/MC/PC48D	1	775	29.6	19.5	18.00	23.50
				2	1175	35.0	24.4		13.25
	TM9X080C16MP11	21.0	FC/MC62D	1	765	29.2	19.1	18.00	23.25
				2	1175	35.4	24.6		13.50
	TM9X080C16MP11	21.0	FC64D	1	775	30.4	20.1	18.50	24.50
				2	1175	36.5	25.4		13.75
	TM9X080C16MP11	21.0	HD48	1	675	28.6	18.0	17.50	23.00
				2	1320	36.0	25.8		13.75
	TM9X080C16MP11	21.0	UC48D	1	775	28.6	18.6	17.00	22.25
				2	1175	33.8	23.0		13.00
	TM9X100C16MP11	21.0	FC/MC/PC48D	1	775	29.6	19.5	18.00	23.50
				2	1175	35.0	24.4		13.25
	TM9X100C16MP11	21.0	FC/MC62D	1	765	29.2	19.1	18.00	23.25
				2	1175	35.4	24.6		13.50
	TM9X100C16MP11	21.0	FC64D	1	775	30.4	20.1	18.50	24.50
				2	1175	36.5	25.4		13.75
	TM9X100C16MP11	21.0	HD48	1	675	28.6	18.0	17.50	23.00
				2	1320	36.0	25.8		13.75
	TM9X100C16MP11	21.0	UC48D	1	775	28.6	18.6	17.00	22.25
				2	1175	33.8	23.0		13.00
	TM9X100C20MP11	21.0	HD48	1	810	29.8	19.5	18.00	23.50
				2	1245	36.0	25.0		14.00
TM9X120D20MP11	24.5	HD48	1	830	29.8	19.8	18.25	23.75	
			2	1260	36.0	25.2		14.00	
L*LC*A12	14.5	FC/MC/PC37A	1	730	28.8	18.5	16.75	21.50	
			2	1150	34.4	23.6		12.75	
L*LC*B12	17.5	FC/MC/PC35B	1	775	28.8	18.7	16.75	21.75	
			2	1150	34.2	23.6		12.75	
L*LC*B12	17.5	FC/MC/PC43B	1	860	29.8	20.1	17.00	22.00	
			2	1275	35.0	24.8		12.50	
L*LC*B12	17.5	HD48	1	750	29.2	18.8	17.50	22.75	
			2	1210	35.4	24.4		13.25	

For Notes See Page 28.

COOLING CAPACITY - With High Efficiency Motor Furnaces (Continued)

UNIT MODEL	FURNACE		COIL MODEL ¹	COOLING					
	MODEL	WIDTH		STAGE	RATED CFM	NET MBH		SEER	EER
						TOTAL	SENS.		
18 SEER AC WITH HIGH EFFICIENCY MOTOR FURNACES²									
AL8B036F4C	L*LC*C16	21.0	FC/MC/PC35C	1	770	29.0	18.8	17.00	22.00
				2	1210	34.4	23.8		13.00
	L*LC*C16	21.0	FC/MC/PC43C	1	770	29.2	19.1	17.25	22.50
				2	1190	35.0	24.4		13.50
	L*LC*C16	21.0	FC/MC/PC48C	1	725	29.2	18.7	17.25	22.50
				2	1195	35.4	24.6		13.75
	L*LC*C16	21.0	FC/PC60C	1	710	29.2	18.8	17.25	22.50
				2	1185	35.0	24.0		13.75
	L*LC*C16	21.0	HD48	1	810	29.8	19.5	18.00	23.25
				2	1210	35.8	24.6		13.75
	L*LC*C16	21.0	UC48C	1	810	28.8	19.1	17.00	22.25
				2	1210	34.8	24.0		13.50
	L*LC*C16	21.0	UC60C	1	810	29.4	19.3	17.50	23.00
				2	1195	35.0	24.4		13.50
	L*LC*C20	21.0	FC/MC/PC35C	1	1020	30.2	21.3	17.25	22.50
				2	1165	34.2	23.6		13.00
	L*LC*C20	21.0	FC/MC/PC43C	1	740	29.0	18.8	17.25	22.50
				2	1190	35.0	24.4		13.50
	L*LC*C20	21.0	FC/MC/PC48C	1	715	29.0	18.6	17.50	22.75
				2	1150	35.2	24.2		13.75
	L*LC*C20	21.0	FC/PC60C	1	800	29.6	19.5	17.75	23.25
				2	1215	35.4	24.8		13.75
	L*LC*C20	21.0	HD48	1	720	29.0	18.5	17.75	23.00
				2	1155	35.4	24.2		13.75
	L*LC*C20	21.0	UC48C	1	720	28.0	18.2	16.75	21.75
				2	1155	34.0	23.2		13.25
	L*LC*C20	21.0	UC60C	1	800	29.4	19.3	17.50	23.00
				2	1215	35.0	24.4		13.50
	L*9C*B12	17.5	FC/MC/PC35B	1	810	28.8	18.7	16.50	21.50
				2	1190	34.2	23.6		12.50
	L*9C*B12	17.5	FC/MC/PC43B	1	815	29.6	19.7	17.00	22.25
				2	1200	34.6	24.2		12.75
	L*9C*B12	17.5	HD48	1	710	28.8	18.3	17.25	22.25
				2	1150	35.0	23.6		13.00
	L*9C*C16	21.0	FC/MC/PC35C	1	790	29.0	18.8	17.00	22.25
				2	1215	34.4	23.6		13.00
	L*9C*C16	21.0	FC/MC/PC43C	1	815	29.6	19.7	17.25	22.50
				2	1240	35.0	24.8		13.00
	L*9C*C16	21.0	FC/MC/PC48C	1	780	29.6	19.5	17.50	23.00
				2	1195	35.0	24.4		13.25
L*9C*C16	21.0	FC/PC60C	1	810	29.6	19.6	17.50	22.75	
			2	1235	35.2	24.8		13.25	
L*9C*C16	21.0	HD48	1	780	29.4	19.1	17.75	23.00	
			2	1195	35.2	24.4		13.25	
L*9C*C16	21.0	UC48C	1	780	28.4	18.5	16.75	21.75	
			2	1195	33.8	23.0		13.00	
L*9C*C16	21.0	UC60C	1	810	29.4	19.5	17.25	22.50	
			2	1235	35.2	24.6		13.25	
L*9C*C20	21.0	FC/MC/PC35C	1	760	28.8	18.8	17.00	22.00	
			2	1330	34.8	24.8		12.75	
L*9C*C20	21.0	FC/MC/PC43C	1	780	29.4	19.3	17.50	22.75	
			2	1200	35.0	24.4		13.25	

For Notes See Page 28.

COOLING CAPACITY - With High Efficiency Motor Furnaces (Continued)

UNIT MODEL	FURNACE		COIL MODEL ¹	COOLING					
	MODEL	WIDTH		STAGE	RATED CFM	NET MBH		SEER	EER
						TOTAL	SENS.		
18 SEER AC WITH HIGH EFFICIENCY MOTOR FURNACES²									
AL8B036F4C	L*9C*C20	21.0	FC/MC/PC48C	1	745	29.2	18.9	17.50	22.75
				2	1330	35.8	25.8		13.25
	L*9C*C20	21.0	FC/PC60C	1	770	29.4	19.2	17.50	23.00
				2	1330	35.6	25.6		13.25
	L*9C*C20	21.0	HD48	1	745	29.2	18.8	17.50	22.75
				2	1330	36.0	25.4		13.25
	L*9C*C20	21.0	UC48C	1	755	28.4	18.4	16.50	21.75
				2	1330	34.4	24.9		12.75
	L*9C*C20	21.0	UC60C	1	770	29.2	19.1	17.50	22.75
				2	1330	35.6	25.6		13.25
	L*9C*D20	24.5	FC/MC/PC48D	1	830	30.0	19.9	17.75	23.25
				2	1240	35.6	25.2		13.50
	L*9C*D20	24.5	FC/MC/PC60D	1	830	29.8	19.9	17.75	23.25
				2	1225	35.4	24.8		13.50
	L*9C*D20	24.5	FC/MC62D	1	835	30.0	20.1	18.00	23.25
				2	1235	35.8	25.4		13.75
	L*9C*D20	24.5	FC64D	1	835	30.6	20.7	18.50	24.25
				2	1235	37.0	26.4		14.00
	L*9C*D20	24.5	HD48	1	830	29.8	19.7	17.75	23.25
				2	1225	35.8	24.6		13.75
L*9C*D20	24.5	UC48D	1	830	29.0	19.4	17.00	22.25	
			2	1240	34.4	24.0		13.25	
L*9C*D20	24.5	UC60D	1	830	29.6	19.7	17.50	23.00	
			2	1225	35.2	24.8		13.50	
AL8B048F4C	T*(8,L)V*C16	21.0	FC/MC/PC48C	1	1120	40.0	26.0	16.00	21.75
				2	1565	45.0	30.4		11.75
	T*(8,L)V*C16	21.0	FC/MC/PC48D	1	1120	40.0	26.0	16.00	21.75
				2	1565	45.0	30.4		11.75
	T*(8,L)V*C16	21.0	FC/MC/PC60D	1	1025	39.0	25.0	15.75	21.50
				2	1600	45.0	31.0		12.00
	T*(8,L)V*C16	21.0	FC/MC62D	1	1025	39.0	25.2	16.00	21.75
				2	1635	46.0	31.8		12.25
	T*(8,L)V*C16	21.0	FC/PC60C	1	1025	39.0	25.0	15.75	21.50
				2	1600	45.0	31.0		12.00
	T*(8,L)V*C16	21.0	FC64D	1	1025	40.5	26.8	16.75	23.00
				2	1635	47.0	33.1		12.75
	T*(8,L)V*C16	21.0	HD60	1	1035	39.5	25.6	16.25	22.00
				2	1625	46.0	31.6		12.50
	T*(8,L)V*C16	21.0	UC48C	1	1035	37.8	24.4	15.00	20.75
				2	1615	44.0	29.8		11.75
	T*(8,L)V*C16	21.0	UC60C	1	1035	39.0	24.8	15.75	21.50
				2	1625	45.0	30.8		12.00
	T*(8,L)V*C20	21.0	FC/MC/PC48C	1	1080	39.0	25.2	16.00	21.75
				2	1640	45.5	31.4		12.25
T*(8,L)V*C20	21.0	FC/MC/PC48D	1	1080	39.0	25.2	16.00	21.75	
			2	1640	45.5	31.4		12.25	
T*(8,L)V*C20	21.0	FC/MC/PC60D	1	1060	39.0	25.0	15.75	21.50	
			2	1625	45.0	31.0		12.25	
T*(8,L)V*C20	21.0	FC/MC62D	1	1060	39.5	25.6	16.00	22.00	
			2	1620	46.0	31.8		12.50	

For Notes See Page 28.

COOLING CAPACITY - With High Efficiency Motor Furnaces (Continued)

UNIT MODEL	FURNACE		COIL MODEL ¹	COOLING					
	MODEL	WIDTH		STAGE	RATED CFM	NET MBH		SEER	EER
						TOTAL	SENS.		
18 SEER AC WITH HIGH EFFICIENCY MOTOR FURNACES²									
AL8B048F4C	T*(8,L)V*C20	21.0	FC/PC60C	1	1060	39.0	25.0	15.75	21.50
				2	1625	45.0	31.0		12.25
	T*(8,L)V*C20	21.0	FC64D	1	1060	40.5	26.8	16.75	23.00
				2	1630	47.5	33.2		12.75
	T*(8,L)V*C20	21.0	HD60	1	1015	39.5	25.4	16.25	22.25
				2	1605	46.5	31.6		12.50
	T*(8,L)V*C20	21.0	UC48C	1	1080	38.5	24.8	15.00	20.75
				2	1640	44.5	30.0		12.00
	T*(8,L)V*C20	21.0	UC60C	1	1015	38.5	24.8	16.00	21.75
				2	1605	45.5	31.0		12.50
	T*9V*C16	21.0	FC/MC/PC48C	1	1050	39.0	25.2	15.75	21.50
				2	1590	45.5	31.2		12.00
	T*9V*C16	21.0	FC/MC/PC48D	1	1050	39.0	25.2	15.75	21.50
				2	1590	45.5	31.2		12.00
	T*9V*C16	21.0	FC/MC/PC60D	1	1050	39.0	25.0	15.75	21.25
				2	1590	45.0	31.0		12.00
	T*9V*C16	21.0	FC/MC62D	1	1040	39.0	25.2	16.00	21.50
				2	1590	46.0	31.4		12.25
	T*9V*C16	21.0	FC/PC60C	1	1050	39.0	25.0	15.75	21.25
				2	1590	45.0	31.0		12.00
	T*9V*C16	21.0	FC64D	1	1040	40.5	26.8	16.50	22.75
				2	1590	47.0	33.1		12.50
	T*9V*C16	21.0	HD60	1	1050	39.5	25.6	16.00	21.75
				2	1590	46.0	31.2		12.25
	T*9V*C16	21.0	UC48C	1	1050	37.6	24.2	15.00	20.25
				2	1590	43.5	29.0		11.50
	T*9V*C16	21.0	UC60C	1	1050	38.5	24.6	15.50	21.00
				2	1590	44.5	29.8		11.75
	T*9V*C20	21.0	FC/MC/PC48C	1	1055	39.0	25.2	15.75	21.50
				2	1655	45.5	31.2		12.00
	T*9V*C20	21.0	FC/MC/PC48D	1	1055	39.0	25.2	15.75	21.50
				2	1655	45.5	31.2		12.00
	T*9V*C20	21.0	FC/MC/PC60D	1	1055	39.0	25.0	15.75	21.50
				2	1655	45.0	31.0		12.00
	T*9V*C20	21.0	FC/MC62D	1	1040	39.0	25.2	16.00	21.75
				2	1655	46.0	31.8		12.00
T*9V*C20	21.0	FC/PC60C	1	1055	39.0	25.0	15.75	21.50	
			2	1655	45.0	31.0		12.00	
T*9V*C20	21.0	FC64D	1	1040	40.5	26.8	16.75	22.75	
			2	1655	47.0	32.9		12.25	
T*9V*C20	21.0	HD60	1	1055	39.5	25.6	16.25	22.00	
			2	1655	46.0	31.8		12.25	
T*9V*C20	21.0	UC48C	1	1055	37.8	24.4	15.00	20.50	
			2	1655	44.0	30.0		11.75	
T*9V*C20	21.0	UC60C	1	1055	38.5	25.0	15.75	21.25	
			2	1655	45.0	31.0		12.00	
T*9V*D20	24.5	FC/MC/PC48D	1	1060	39.0	25.2	15.75	21.50	
			2	1645	45.5	31.2		12.00	
T*9V*D20	24.5	FC/MC/PC60D	1	1070	39.0	25.0	15.75	21.50	
			2	1615	45.0	31.0		12.00	
T*9V*D20	24.5	FC/MC62D	1	1085	39.5	25.6	16.00	21.75	
			2	1630	46.0	31.6		12.25	

For Notes See Page 28.

COOLING CAPACITY - With High Efficiency Motor Furnaces (Continued)

UNIT MODEL	FURNACE		COIL MODEL ¹	COOLING					
	MODEL	WIDTH		STAGE	RATED CFM	NET MBH		SEER	EER
						TOTAL	SENS.		
18 SEER AC WITH HIGH EFFICIENCY MOTOR FURNACES²									
AL8B048F4C	T*9V*D20	24.5	FC64D	1	1085	40.5	26.8	16.50	22.50
				2	1630	47.0	32.9		12.50
	T*9V*D20	24.5	HD60	1	1070	40.0	26.4	16.25	22.25
				2	1615	46.0	31.4		12.25
	T*9V*D20	24.5	UC48D	1	1060	37.8	24.4	15.00	20.50
				2	1645	44.0	30.0		11.75
	T*9V*D20	24.5	UC60D	1	1070	39.0	25.2	15.75	21.25
				2	1615	45.0	30.6		12.00
	TM8X080C16MP11	21.0	FC/MC/PC48C	1	1030	39.5	25.2	16.25	22.25
				2	1525	45.0	30.2		12.00
	TM8X080C16MP11	21.0	FC/MC/PC48D	1	1045	39.5	25.2	16.25	22.25
				2	1550	45.5	31.4		12.25
	TM8X080C16MP11	21.0	FC/MC/PC60D	1	1045	39.0	25.0	16.25	22.25
				2	1550	45.0	31.0		12.25
	TM8X080C16MP11	21.0	FC/MC62D	1	1040	39.0	25.4	16.50	22.25
				2	1550	45.5	31.0		12.25
	TM8X080C16MP11	21.0	FC/PC60C	1	1020	39.0	25.0	16.00	22.00
				2	1525	44.5	29.8		12.00
	TM8X080C16MP11	21.0	FC64D	1	1045	41.0	26.8	17.00	23.50
				2	1550	47.0	33.1		12.50
	TM8X080C16MP11	21.0	HD60	1	1115	40.0	26.4	16.50	22.50
				2	1610	46.5	31.6		12.50
	TM8X080C16MP11	21.0	UC48C	1	1030	37.8	24.4	15.50	21.25
				2	1525	43.5	29.0		11.75
	TM8X080C16MP11	21.0	UC48D	1	1045	37.8	24.4	15.50	21.25
				2	1550	43.5	29.0		11.75
	TM8X080C16MP11	21.0	UC60C	1	1020	38.5	24.8	16.00	21.75
				2	1525	44.5	29.8		12.00
	TM8X080C16MP11	21.0	UC60D	1	1045	38.5	24.8	16.00	21.75
				2	1550	44.5	29.8		12.00
	TM8X100C16MP11	21.0	FC/MC/PC48C	1	1030	39.5	25.2	16.25	22.25
				2	1525	45.0	30.2		12.00
	TM8X100C16MP11	21.0	FC/MC/PC48D	1	1045	39.5	25.2	16.25	22.25
				2	1550	45.5	31.4		12.25
	TM8X100C16MP11	21.0	FC/MC/PC60D	1	1045	39.0	25.0	16.25	22.25
				2	1550	45.0	31.0		12.25
	TM8X100C16MP11	21.0	FC/MC62D	1	1040	39.0	25.4	16.50	22.25
				2	1550	45.5	31.0		12.25
	TM8X100C16MP11	21.0	FC/PC60C	1	1020	39.0	25.0	16.00	22.00
				2	1525	44.5	29.8		12.00
TM8X100C16MP11	21.0	FC64D	1	1045	41.0	26.8	17.00	23.50	
			2	1550	47.0	33.1		12.50	
TM8X100C16MP11	21.0	HD60	1	1115	40.0	26.4	16.50	22.50	
			2	1610	46.5	31.6		12.50	
TM8X100C16MP11	21.0	UC48C	1	1030	37.8	24.4	15.50	21.25	
			2	1525	43.5	29.0		11.75	
TM8X100C16MP11	21.0	UC48D	1	1045	37.8	24.4	15.50	21.25	
			2	1550	43.5	29.0		11.75	
TM8X100C16MP11	21.0	UC60C	1	1020	38.5	24.8	16.00	21.75	
			2	1525	44.5	29.8		12.00	

For Notes See Page 28.

COOLING CAPACITY - With High Efficiency Motor Furnaces (Continued)

UNIT MODEL	FURNACE		COIL MODEL ¹	COOLING					
	MODEL	WIDTH		STAGE	RATED CFM	NET MBH		SEER	EER
						TOTAL	SENS.		
18 SEER AC WITH HIGH EFFICIENCY MOTOR FURNACES²									
AL8B048F4C	TM8X100C16MP11	21.0	UC60D	1	1045	38.5	24.8	16.00	21.75
				2	1550	44.5	29.8		12.00
	TM8X100C20MP11	21.0	FC/MC/PC48C	1	1090	39.5	25.8	16.25	22.25
				2	1550	45.0	30.6		12.25
	TM8X100C20MP11	21.0	FC/MC/PC48D	1	1105	40.0	26.0	16.25	22.50
				2	1575	45.5	30.8		12.25
	TM8X100C20MP11	21.0	FC/MC/PC60D	1	1105	39.5	25.8	16.25	22.25
				2	1575	45.0	30.6		12.25
	TM8X100C20MP11	21.0	FC/MC62D	1	1100	40.0	26.2	16.50	22.25
				2	1575	46.0	31.2		12.50
	TM8X100C20MP11	21.0	FC/PC60C	1	1085	39.0	25.0	16.00	21.75
				2	1550	45.5	31.0		12.25
	TM8X100C20MP11	21.0	HD60	1	835	37.6	23.4	16.00	21.75
				2	1665	46.5	32.4		12.75
	TM8X100C20MP11	21.0	UC48C	1	1090	38.5	24.8	15.50	21.25
				2	1550	44.0	29.4		12.00
	TM8X100C20MP11	21.0	UC48D	1	1105	38.5	24.8	15.50	21.50
				2	1575	44.0	29.8		12.00
	TM8X100C20MP11	21.0	UC60C	1	1085	39.0	25.4	16.00	22.00
				2	1550	45.0	30.2		12.25
	TM8X100C20MP11	21.0	UC60D	1	1105	39.5	25.6	16.25	22.00
				2	1575	45.0	30.6		12.25
	TM8X120C20MP11	21.0	FC/MC/PC48C	1	1090	39.5	25.8	16.25	22.25
				2	1550	45.0	30.6		12.25
	TM8X120C20MP11	21.0	FC/MC/PC48D	1	1105	40.0	26.0	16.25	22.50
				2	1575	45.5	30.8		12.25
	TM8X120C20MP11	21.0	FC/MC/PC60D	1	1105	39.5	25.8	16.25	22.25
				2	1575	45.0	30.6		12.25
	TM8X120C20MP11	21.0	FC/MC62D	1	1100	40.0	26.2	16.50	22.25
				2	1575	46.0	31.2		12.50
	TM8X120C20MP11	21.0	FC/PC60C	1	1085	39.0	25.0	16.00	21.75
				2	1550	45.5	31.0		12.25
	TM8X120C20MP11	21.0	HD60	1	835	37.6	23.4	16.00	21.75
				2	1665	46.5	32.4		12.75
	TM8X120C20MP11	21.0	UC48C	1	1090	38.5	24.8	15.50	21.25
				2	1550	44.0	29.4		12.00
	TM8X120C20MP11	21.0	UC48D	1	1105	38.5	24.8	15.50	21.50
				2	1575	44.0	29.8		12.00
	TM8X120C20MP11	21.0	UC60C	1	1085	39.0	25.4	16.00	22.00
				2	1550	45.0	30.2		12.25
TM8X120C20MP11	21.0	UC60D	1	1105	39.5	25.6	16.25	22.00	
			2	1575	45.0	30.6		12.25	
TMLX080C16MP11	21.0	FC/MC/PC48C	1	1030	39.5	25.2	16.25	22.25	
			2	1525	45.0	30.2		12.00	
TMLX080C16MP11	21.0	FC/MC/PC48D	1	1045	39.5	25.2	16.25	22.25	
			2	1550	45.5	31.4		12.25	
TMLX080C16MP11	21.0	FC/MC/PC60D	1	1045	39.0	25.0	16.25	22.25	
			2	1550	45.0	31.0		12.25	
TMLX080C16MP11	21.0	FC/MC62D	1	1040	39.0	25.4	16.50	22.25	
			2	1550	45.5	31.0		12.25	
TMLX080C16MP11	21.0	FC/PC60C	1	1020	39.0	25.0	16.00	22.00	
			2	1525	44.5	29.8		12.00	

For Notes See Page 28.

COOLING CAPACITY - With High Efficiency Motor Furnaces (Continued)

UNIT MODEL	FURNACE		COIL MODEL ¹	COOLING					
	MODEL	WIDTH		STAGE	RATED CFM	NET MBH		SEER	EER
						TOTAL	SENS.		
18 SEER AC WITH HIGH EFFICIENCY MOTOR FURNACES²									
AL8B048F4C	TMLX080C16MP11	21.0	FC64D	1	1045	41.0	26.8	17.00	23.50
				2	1550	47.0	33.1		12.50
	TMLX080C16MP11	21.0	HD60	1	1115	40.0	26.4	16.50	22.50
				2	1610	46.5	31.6		12.50
	TMLX080C16MP11	21.0	UC48C	1	1030	37.8	24.4	15.50	21.25
				2	1525	43.5	29.0		11.75
	TMLX080C16MP11	21.0	UC48D	1	1045	37.8	24.4	15.50	21.25
				2	1550	43.5	29.0		11.75
	TMLX080C16MP11	21.0	UC60C	1	1020	38.5	24.8	16.00	21.75
				2	1525	44.5	29.8		12.00
	TMLX080C16MP11	21.0	UC60D	1	1045	38.5	24.8	16.00	21.75
				2	1550	44.5	29.8		12.00
	TMLX100C16MP11	21.0	FC/MC/PC48C	1	1030	39.5	25.2	16.25	22.25
				2	1525	45.0	30.2		12.00
	TMLX100C16MP11	21.0	FC/MC/PC48D	1	1045	39.5	25.2	16.25	22.25
				2	1550	45.5	31.4		12.25
	TMLX100C16MP11	21.0	FC/MC/PC60D	1	1045	39.0	25.0	16.25	22.25
				2	1550	45.0	31.0		12.25
	TMLX100C16MP11	21.0	FC/MC62D	1	1040	39.0	25.4	16.50	22.25
				2	1550	45.5	31.0		12.25
	TMLX100C16MP11	21.0	FC/PC60C	1	1020	39.0	25.0	16.00	22.00
				2	1525	44.5	29.8		12.00
	TMLX100C16MP11	21.0	FC64D	1	1045	41.0	26.8	17.00	23.50
				2	1550	47.0	33.1		12.50
	TMLX100C16MP11	21.0	HD60	1	1115	40.0	26.4	16.50	22.50
				2	1610	46.5	31.6		12.50
	TMLX100C16MP11	21.0	UC48C	1	1030	37.8	24.4	15.50	21.25
				2	1525	43.5	29.0		11.75
	TMLX100C16MP11	21.0	UC48D	1	1045	37.8	24.4	15.50	21.25
				2	1550	43.5	29.0		11.75
	TMLX100C16MP11	21.0	UC60C	1	1020	38.5	24.8	16.00	21.75
				2	1525	44.5	29.8		12.00
	TMLX100C16MP11	21.0	UC60D	1	1045	38.5	24.8	16.00	21.75
				2	1550	44.5	29.8		12.00
	TMLX100C20MP11	21.0	FC/MC/PC48C	1	1090	39.5	25.8	16.25	22.25
				2	1550	45.0	30.6		12.25
	TMLX100C20MP11	21.0	FC/MC/PC48D	1	1105	40.0	26.0	16.25	22.50
				2	1575	45.5	30.8		12.25
	TMLX100C20MP11	21.0	FC/MC/PC60D	1	1105	39.5	25.8	16.25	22.25
				2	1575	45.0	30.6		12.25
TMLX100C20MP11	21.0	FC/MC62D	1	1100	40.0	26.2	16.50	22.25	
			2	1575	46.0	31.2		12.50	
TMLX100C20MP11	21.0	FC/PC60C	1	1085	39.0	25.0	16.00	21.75	
			2	1550	45.5	31.0		12.25	
TMLX100C20MP11	21.0	HD60	1	835	37.6	23.4	16.00	21.75	
			2	1665	46.5	32.4		12.75	
TMLX100C20MP11	21.0	UC48C	1	1090	38.5	24.8	15.50	21.25	
			2	1550	44.0	29.4		12.00	
TMLX100C20MP11	21.0	UC48D	1	1105	38.5	24.8	15.50	21.50	
			2	1575	44.0	29.8		12.00	

For Notes See Page 28.

COOLING CAPACITY - With High Efficiency Motor Furnaces (Continued)

UNIT MODEL	FURNACE		COIL MODEL ¹	COOLING					
	MODEL	WIDTH		STAGE	RATED CFM	NET MBH		SEER	EER
						TOTAL	SENS.		
18 SEER AC WITH HIGH EFFICIENCY MOTOR FURNACES²									
AL8B048F4C	TMLX100C20MP11	21.0	UC60C	1	1085	39.0	25.4	16.00	22.00
				2	1550	45.0	30.2		12.25
	TMLX100C20MP11	21.0	UC60D	1	1105	39.5	25.6	16.25	22.00
				2	1575	45.0	30.6		12.25
	TMLX120C20MP11	21.0	FC/MC/PC48C	1	1090	39.5	25.8	16.25	22.25
				2	1550	45.0	30.6		12.25
	TMLX120C20MP11	21.0	FC/MC/PC48D	1	1105	40.0	26.0	16.25	22.50
				2	1575	45.5	30.8		12.25
	TMLX120C20MP11	21.0	FC/MC/PC60D	1	1105	39.5	25.8	16.25	22.25
				2	1575	45.0	30.6		12.25
	TMLX120C20MP11	21.0	FC/MC62D	1	1100	40.0	26.2	16.50	22.25
				2	1575	46.0	31.2		12.50
	TMLX120C20MP11	21.0	FC/PC60C	1	1085	39.0	25.0	16.00	21.75
				2	1550	45.5	31.0		12.25
	TMLX120C20MP11	21.0	HD60	1	835	37.6	23.4	16.00	21.75
				2	1665	46.5	32.4		12.75
	TMLX120C20MP11	21.0	UC48C	1	1090	38.5	24.8	15.50	21.25
				2	1550	44.0	29.4		12.00
	TMLX120C20MP11	21.0	UC48D	1	1105	38.5	24.8	15.50	21.50
				2	1575	44.0	29.8		12.00
	TMLX120C20MP11	21.0	UC60C	1	1085	39.0	25.4	16.00	22.00
				2	1550	45.0	30.2		12.25
	TMLX120C20MP11	21.0	UC60D	1	1105	39.5	25.6	16.25	22.00
				2	1575	45.0	30.6		12.25
	TM9E080C16MP11	21.0	HD60	1	1085	40.0	26.4	16.50	22.50
				2	1575	46.5	31.6		12.50
	TM9E100C16MP11	21.0	HD60	1	1085	40.0	26.4	16.50	22.50
				2	1575	46.5	31.6		12.50
	TM9E100C20MP11	21.0	FC/MC/PC48C	1	945	38.5	24.2	16.00	21.75
				2	1500	44.5	30.0		11.75
	TM9E100C20MP11	21.0	FC/MC/PC48D	1	960	38.5	24.4	16.25	22.00
				2	1525	45.0	30.2		12.00
	TM9E100C20MP11	21.0	FC/MC/PC60D	1	960	38.5	24.4	16.00	22.00
				2	1525	44.5	29.8		12.00
	TM9E100C20MP11	21.0	FC/MC62D	1	985	39.0	24.8	16.25	22.25
				2	1550	45.5	31.0		12.25
TM9E100C20MP11	21.0	FC64D	1	980	40.0	25.8	17.00	23.25	
			2	1550	47.0	32.2		12.50	
TM9E100C20MP11	21.0	HD60	1	1220	41.0	26.8	16.50	22.50	
			2	1625	46.5	31.8		12.75	
TM9E100C20MP11	21.0	UC48C	1	945	37.0	23.4	15.25	20.75	
			2	1500	43.5	28.8		11.50	
TM9E100C20MP11	21.0	UC48D	1	960	37.4	23.6	15.25	21.00	
			2	1525	43.5	29.0		11.75	
TM9E100C20MP11	21.0	UC60D	1	960	38.5	24.2	16.00	21.75	
			2	1525	44.5	29.8		12.00	
TM9E120D20MP11	24.5	FC/MC/PC48D	1	965	38.5	24.6	16.25	22.00	
			2	1525	45.0	30.4		12.25	
TM9E120D20MP11	24.5	FC/MC/PC60D	1	980	39.0	24.6	16.25	22.25	
			2	1550	45.0	30.2		12.25	
TM9E120D20MP11	24.5	FC/MC62D	1	980	39.0	24.8	16.25	22.25	
			2	1550	45.5	31.0		12.25	

For Notes See Page 28.

COOLING CAPACITY - With High Efficiency Motor Furnaces (Continued)

UNIT MODEL	FURNACE		COIL MODEL ¹	COOLING					
	MODEL	WIDTH		STAGE	RATED CFM	NET MBH		SEER	EER
						TOTAL	SENS.		
18 SEER AC WITH HIGH EFFICIENCY MOTOR FURNACES²									
AL8B048F4C	TM9E120D20MP11	24.5	FC64D	1	960	40.0	25.6	16.75	23.25
				2	1525	46.5	31.8		12.50
	TM9E120D20MP11	24.5	HD60	1	1240	41.0	27.8	16.50	22.50
				2	1645	46.5	32.0		12.75
	TM9E120D20MP11	24.5	UC48D	1	965	37.2	23.6	15.50	21.00
				2	1525	43.5	29.0		11.75
	TM9E120D20MP11	24.5	UC60D	1	980	39.0	24.8	16.25	22.25
				2	1550	44.5	30.0		12.00
	TM9X080C16MP11	21.0	HD60	1	1085	40.0	26.4	16.50	22.50
				2	1575	46.5	31.6		12.50
	TM9X100C16MP11	21.0	HD60	1	1085	40.0	26.4	16.50	22.50
				2	1575	46.5	31.6		12.50
	TM9X100C20MP11	21.0	FC/MC/PC48C	1	945	38.5	24.2	16.00	21.75
				2	1500	44.5	30.0		11.75
	TM9X100C20MP11	21.0	FC/MC/PC48D	1	960	38.5	24.4	16.25	22.00
				2	1525	45.0	30.2		12.00
	TM9X100C20MP11	21.0	FC/MC/PC60D	1	960	38.5	24.4	16.00	22.00
				2	1525	44.5	29.8		12.00
	TM9X100C20MP11	21.0	FC/MC62D	1	985	39.0	24.8	16.25	22.25
				2	1550	45.5	31.0		12.25
	TM9X100C20MP11	21.0	FC64D	1	980	40.0	25.8	17.00	23.25
				2	1550	47.0	32.2		12.50
	TM9X100C20MP11	21.0	HD60	1	1220	41.0	26.8	16.50	22.50
				2	1625	46.5	31.8		12.75
	TM9X100C20MP11	21.0	UC48C	1	945	37.0	23.4	15.25	20.75
				2	1500	43.5	28.8		11.50
	TM9X100C20MP11	21.0	UC48D	1	960	37.4	23.6	15.25	21.00
				2	1525	43.5	29.0		11.75
	TM9X100C20MP11	21.0	UC60D	1	960	38.5	24.2	16.00	21.75
				2	1525	44.5	29.8		12.00
	TM9X120D20MP11	24.5	FC/MC/PC48D	1	965	38.5	24.6	16.25	22.00
				2	1525	45.0	30.4		12.25
	TM9X120D20MP11	24.5	FC/MC/PC60D	1	980	39.0	24.6	16.25	22.25
				2	1550	45.0	30.2		12.25
	TM9X120D20MP11	24.5	FC/MC62D	1	980	39.0	24.8	16.25	22.25
				2	1550	45.5	31.0		12.25
	TM9X120D20MP11	24.5	FC64D	1	960	40.0	25.6	16.75	23.25
				2	1525	46.5	31.8		12.50
	TM9X120D20MP11	24.5	HD60	1	1240	41.0	27.8	16.50	22.50
				2	1645	46.5	32.0		12.75
TM9X120D20MP11	24.5	UC48D	1	965	37.2	23.6	15.50	21.00	
			2	1525	43.5	29.0		11.75	
TM9X120D20MP11	24.5	UC60D	1	980	39.0	24.8	16.25	22.25	
			2	1550	44.5	30.0		12.00	
L*LC*C16	21.0	FC/MC/PC48C	1	1120	40.0	26.0	16.00	21.75	
			2	1565	45.0	30.4		11.75	
L*LC*C16	21.0	FC/MC/PC48D	1	1120	40.0	26.0	16.00	21.75	
			2	1565	45.0	30.4		11.75	
L*LC*C16	21.0	FC/MC/PC60D	1	1025	39.0	25.0	15.75	21.50	
			2	1600	45.0	31.0		12.00	

For Notes See Page 28.

COOLING CAPACITY - With High Efficiency Motor Furnaces (Continued)

UNIT MODEL	FURNACE		COIL MODEL ¹	COOLING					
	MODEL	WIDTH		STAGE	RATED CFM	NET MBH		SEER	EER
						TOTAL	SENS.		
18 SEER AC WITH HIGH EFFICIENCY MOTOR FURNACES²									
AL8B048F4C	L*LC*C16	21.0	FC/MC62D	1	1025	39.0	25.2	16.00	21.75
				2	1635	46.0	31.8		12.25
	L*LC*C16	21.0	FC/PC60C	1	1025	39.0	25.0	15.75	21.50
				2	1600	45.0	31.0		12.00
	L*LC*C16	21.0	FC64D	1	1025	40.5	26.8	16.75	23.00
				2	1635	47.0	33.1		12.75
	L*LC*C16	21.0	HD60	1	1035	39.5	25.6	16.25	22.00
				2	1625	46.0	31.6		12.50
	L*LC*C16	21.0	UC48C	1	1035	37.8	24.4	15.00	20.75
				2	1615	44.0	29.8		11.75
	L*LC*C16	21.0	UC60C	1	1035	39.0	24.8	15.75	21.50
				2	1625	45.0	30.8		12.00
	L*LC*C20	21.0	FC/MC/PC48C	1	1080	39.0	25.2	16.00	21.75
				2	1640	45.5	31.4		12.25
	L*LC*C20	21.0	FC/MC/PC48D	1	1080	39.0	25.2	16.00	21.75
				2	1640	45.5	31.4		12.25
	L*LC*C20	21.0	FC/MC/PC60D	1	1060	39.0	25.0	15.75	21.50
				2	1625	45.0	31.0		12.25
	L*LC*C20	21.0	FC/MC62D	1	1060	39.5	25.6	16.00	22.00
				2	1620	46.0	31.8		12.50
	L*LC*C20	21.0	FC/PC60C	1	1060	39.0	25.0	15.75	21.50
				2	1625	45.0	31.0		12.25
	L*LC*C20	21.0	FC64D	1	1060	40.5	26.8	16.75	23.00
				2	1630	47.5	33.2		12.75
	L*LC*C20	21.0	HD60	1	1015	39.5	25.4	16.25	22.25
				2	1605	46.5	31.6		12.50
	L*LC*C20	21.0	UC48C	1	1080	38.5	24.8	15.00	20.75
				2	1640	44.5	30.0		12.00
	L*LC*C20	21.0	UC60C	1	1015	38.5	24.8	16.00	21.75
				2	1605	45.5	31.0		12.50
	L*9C*C16	21.0	FC/MC/PC48C	1	1050	39.0	25.2	15.75	21.50
				2	1590	45.5	31.2		12.00
	L*9C*C16	21.0	FC/MC/PC48D	1	1050	39.0	25.2	15.75	21.50
				2	1590	45.5	31.2		12.00
	L*9C*C16	21.0	FC/MC/PC60D	1	1050	39.0	25.0	15.75	21.25
				2	1590	45.0	31.0		12.00
	L*9C*C16	21.0	FC/MC62D	1	1040	39.0	25.2	16.00	21.50
				2	1590	46.0	31.4		12.25
	L*9C*C16	21.0	FC/PC60C	1	1050	39.0	25.0	15.75	21.25
				2	1590	45.0	31.0		12.00
L*9C*C16	21.0	FC64D	1	1040	40.5	26.8	16.50	22.75	
			2	1590	47.0	33.1		12.50	
L*9C*C16	21.0	HD60	1	1050	39.5	25.6	16.00	21.75	
			2	1590	46.0	31.2		12.25	
L*9C*C16	21.0	UC48C	1	1050	37.6	24.2	15.00	20.25	
			2	1590	43.5	29.0		11.50	
L*9C*C16	21.0	UC60C	1	1050	38.5	24.6	15.50	21.00	
			2	1590	44.5	29.8		11.75	
L*9C*C20	21.0	FC/MC/PC48C	1	1055	39.0	25.2	15.75	21.50	
			2	1655	45.5	31.2		12.00	
L*9C*C20	21.0	FC/MC/PC48D	1	1055	39.0	25.2	15.75	21.50	
			2	1655	45.5	31.2		12.00	

For Notes See Page 28.

COOLING CAPACITY - With High Efficiency Motor Furnaces (Continued)

UNIT MODEL	FURNACE		COIL MODEL ¹	COOLING					
	MODEL	WIDTH		STAGE	RATED CFM	NET MBH		SEER	EER
						TOTAL	SENS.		
18 SEER AC WITH HIGH EFFICIENCY MOTOR FURNACES²									
AL8B048F4C	L*9C*C20	21.0	FC/MC/PC60D	1	1055	39.0	25.0	15.75	21.50
				2	1655	45.0	31.0		12.00
	L*9C*C20	21.0	FC/MC62D	1	1040	39.0	25.2	16.00	21.75
				2	1655	46.0	31.8		12.00
	L*9C*C20	21.0	FC/PC60C	1	1055	39.0	25.0	15.75	21.50
				2	1655	45.0	31.0		12.00
	L*9C*C20	21.0	FC64D	1	1040	40.5	26.8	16.75	22.75
				2	1655	47.0	32.9		12.25
	L*9C*C20	21.0	HD60	1	1055	39.5	25.6	16.25	22.00
				2	1655	46.0	31.8		12.25
	L*9C*C20	21.0	UC48C	1	1055	37.8	24.4	15.00	20.50
				2	1655	44.0	30.0		11.75
	L*9C*C20	21.0	UC60C	1	1055	38.5	25.0	15.75	21.25
				2	1655	45.0	31.0		12.00
	L*9C*D20	24.5	FC/MC/PC48D	1	1060	39.0	25.2	15.75	21.50
				2	1645	45.5	31.2		12.00
	L*9C*D20	24.5	FC/MC/PC60D	1	1070	39.0	25.0	15.75	21.50
				2	1615	45.0	31.0		12.00
	L*9C*D20	24.5	FC/MC62D	1	1085	39.5	25.6	16.00	21.75
				2	1630	46.0	31.6		12.25
L*9C*D20	24.5	FC64D	1	1085	40.5	26.8	16.50	22.50	
			2	1630	47.0	32.9		12.50	
L*9C*D20	24.5	HD60	1	1070	40.0	26.4	16.25	22.25	
			2	1615	46.0	31.4		12.25	
L*9C*D20	24.5	UC48D	1	1060	37.8	24.4	15.00	20.50	
			2	1645	44.0	30.0		11.75	
L*9C*D20	24.5	UC60D	1	1070	39.0	25.2	15.75	21.25	
			2	1615	45.0	30.6		12.00	
AL8B060F4C	T*(8,L)V*C16	21.0	FC/PC60C	1	1025	46.0	28.6	14.75	20.00
				2	1600	55.0	36.9		11.25
	T*(8,L)V*C20	21.0	FC/MC/PC60D	1	1060	46.5	29.2	15.00	20.25
				2	1600	55.5	37.1		11.50
	T*(8,L)V*C20	21.0	FC/MC62D	1	1015	46.0	29.0	14.75	19.75
				2	1600	56.0	38.2		11.50
	T*(8,L)V*C20	21.0	FC/PC60C	1	1060	46.5	29.2	15.00	20.25
				2	1600	55.5	37.1		11.50
	T*(8,L)V*C20	21.0	FC64D	1	1060	48.0	30.4	15.50	21.00
				2	1855	58.5	41.6		11.75
	T*(8,L)V*C20	21.0	HD60	1	1015	46.0	29.2	15.00	20.25
				2	1605	56.0	37.7		11.75
	T*(8,L)V*C20	21.0	UC60C	1	1015	45.5	28.4	15.00	20.00
				2	1605	55.5	37.3		11.50
	T*9V*C20	21.0	FC/MC/PC60D	1	1055	46.5	29.0	15.00	20.00
				2	1655	55.5	37.5		11.25
	T*9V*C20	21.0	FC/MC62D	1	1040	46.0	29.2	15.00	20.00
				2	1655	56.0	38.2		11.50
	T*9V*C20	21.0	FC/PC60C	1	1055	46.5	29.0	15.00	20.00
				2	1655	55.5	37.5		11.25
T*9V*C20	21.0	FC64D	1	1040	48.0	30.2	15.50	20.75	
			2	1655	57.5	39.7		11.75	

For Notes See Page 28.

COOLING CAPACITY - With High Efficiency Motor Furnaces (Continued)

UNIT MODEL	FURNACE		COIL MODEL ¹	COOLING					
	MODEL	WIDTH		STAGE	RATED CFM	NET MBH		SEER	EER
						TOTAL	SENS.		
18 SEER AC WITH HIGH EFFICIENCY MOTOR FURNACES²									
AL8B060F4C	T*9V*C20	21.0	HD60	1	1055	46.5	29.8	15.00	20.00
				2	1655	55.5	38.2		11.50
	T*9V*C20	21.0	UC60C	1	1055	46.0	28.8	14.75	19.75
				2	1655	55.5	37.5		11.25
	T*9V*D20	24.5	FC/MC/PC60D	1	1070	46.5	29.2	15.00	20.00
				2	1615	55.5	37.1		11.50
	T*9V*D20	24.5	FC/MC62D	1	1085	47.0	29.8	15.00	20.00
				2	1630	56.0	38.2		11.50
	T*9V*D20	24.5	FC64D	1	1085	48.5	30.8	15.50	21.00
				2	1630	57.5	39.2		11.75
	T*9V*D20	24.5	HD60	1	1070	46.5	29.8	15.00	20.00
				2	1615	56.0	37.7		11.50
	T*9V*D20	24.5	UC60D	1	1070	46.0	29.0	14.75	19.75
				2	1615	55.0	37.1		11.25
	TM8X080C16MP11	21.0	FC/MC/PC60D	1	1045	46.5	29.0	15.25	20.50
				2	1550	55.0	36.5		11.25
	TM8X080C16MP11	21.0	FC/MC62D	1	1040	46.5	29.4	15.25	20.50
				2	1550	55.5	37.5		11.50
	TM8X080C16MP11	21.0	FC/PC60C	1	1020	46.0	28.8	15.00	20.25
				2	1525	54.5	36.3		11.25
	TM8X080C16MP11	21.0	FC64D	1	1045	48.0	30.4	15.75	21.50
				2	1550	57.0	38.7		11.75
	TM8X080C16MP11	21.0	UC60C	1	1020	45.5	28.4	15.00	20.00
				2	1525	54.5	36.1		11.25
	TM8X080C16MP11	21.0	UC60D	1	1045	45.5	28.4	15.00	20.00
				2	1550	54.5	36.1		11.25
	TM8X100C16MP11	21.0	FC/MC/PC60D	1	1045	46.5	29.0	15.25	20.50
				2	1550	55.0	36.5		11.25
	TM8X100C16MP11	21.0	FC/MC62D	1	1040	46.5	29.4	15.25	20.50
				2	1550	55.5	37.5		11.50
	TM8X100C16MP11	21.0	FC/PC60C	1	1020	46.0	28.8	15.00	20.25
				2	1525	54.5	36.3		11.25
	TM8X100C16MP11	21.0	FC64D	1	1045	48.0	30.4	15.75	21.50
				2	1550	57.0	38.7		11.75
	TM8X100C16MP11	21.0	UC60C	1	1020	45.5	28.4	15.00	20.00
				2	1525	54.5	36.1		11.25
	TM8X100C16MP11	21.0	UC60D	1	1045	45.5	28.4	15.00	20.00
				2	1550	54.5	36.1		11.25
	TM8X100C20MP11	21.0	FC/MC/PC60D	1	1105	47.0	29.8	15.25	20.50
				2	1575	55.5	36.9		11.50
TM8X100C20MP11	21.0	FC/MC62D	1	1100	47.0	30.0	15.25	20.50	
			2	1575	56.0	37.7		11.50	
TM8X100C20MP11	21.0	FC/PC60C	1	1085	47.0	29.4	15.25	20.50	
			2	1550	55.0	36.7		11.50	
TM8X100C20MP11	21.0	HD60	1	1255	48.5	32.0	15.50	21.00	
			2	1665	56.5	39.2		12.00	
TM8X100C20MP11	21.0	UC60C	1	1085	46.5	29.2	15.00	20.25	
			2	1550	55.0	36.5		11.50	
TM8X100C20MP11	21.0	UC60D	1	1105	46.5	29.6	15.25	20.50	
			2	1575	55.0	36.9		11.50	
TM8X120C20MP11	21.0	FC/MC/PC60D	1	1105	47.0	29.8	15.25	20.50	
			2	1575	55.5	36.9		11.50	

For Notes See Page 28.

COOLING CAPACITY - With High Efficiency Motor Furnaces (Continued)

UNIT MODEL	FURNACE		COIL MODEL ¹	COOLING					
	MODEL	WIDTH		STAGE	RATED CFM	NET MBH		SEER	EER
						TOTAL	SENS.		
18 SEER AC WITH HIGH EFFICIENCY MOTOR FURNACES²									
AL8B060F4C	TM8X120C20MP11	21.0	FC/MC62D	1	1100	47.0	30.0	15.25	20.50
				2	1575	56.0	37.7		11.50
	TM8X120C20MP11	21.0	FC/PC60C	1	1085	47.0	29.4	15.25	20.50
				2	1550	55.0	36.7		11.50
	TM8X120C20MP11	21.0	HD60	1	1255	48.5	32.0	15.50	21.00
				2	1665	56.5	39.2		12.00
	TM8X120C20MP11	21.0	UC60C	1	1085	46.5	29.2	15.00	20.25
				2	1550	55.0	36.5		11.50
	TM8X120C20MP11	21.0	UC60D	1	1105	46.5	29.6	15.25	20.50
				2	1575	55.0	36.9		11.50
	TMLX080C16MP11	21.0	FC/MC/PC60D	1	1045	46.5	29.0	15.25	20.50
				2	1550	55.0	36.5		11.25
	TMLX080C16MP11	21.0	FC/MC62D	1	1040	46.5	29.4	15.25	20.50
				2	1550	55.5	37.5		11.50
	TMLX080C16MP11	21.0	FC/PC60C	1	1020	46.0	28.8	15.00	20.25
				2	1525	54.5	36.3		11.25
	TMLX080C16MP11	21.0	FC64D	1	1045	48.0	30.4	15.75	21.50
				2	1550	57.0	38.7		11.75
	TMLX080C16MP11	21.0	UC60C	1	1020	45.5	28.4	15.00	20.00
				2	1525	54.5	36.1		11.25
	TMLX080C16MP11	21.0	UC60D	1	1045	45.5	28.4	15.00	20.00
				2	1550	54.5	36.1		11.25
	TMLX100C16MP11	21.0	FC/MC/PC60D	1	1045	46.5	29.0	15.25	20.50
				2	1550	55.0	36.5		11.25
	TMLX100C16MP11	21.0	FC/MC62D	1	1040	46.5	29.4	15.25	20.50
				2	1550	55.5	37.5		11.50
	TMLX100C16MP11	21.0	FC/PC60C	1	1020	46.0	28.8	15.00	20.25
				2	1525	54.5	36.3		11.25
	TMLX100C16MP11	21.0	FC64D	1	1045	48.0	30.4	15.75	21.50
				2	1550	57.0	38.7		11.75
	TMLX100C16MP11	21.0	UC60C	1	1020	45.5	28.4	15.00	20.00
				2	1525	54.5	36.1		11.25
	TMLX100C16MP11	21.0	UC60D	1	1045	45.5	28.4	15.00	20.00
				2	1550	54.5	36.1		11.25
	TMLX100C20MP11	21.0	FC/MC/PC60D	1	1105	47.0	29.8	15.25	20.50
				2	1575	55.5	36.9		11.50
	TMLX100C20MP11	21.0	FC/MC62D	1	1100	47.0	30.0	15.25	20.50
				2	1575	56.0	37.7		11.50
	TMLX100C20MP11	21.0	FC/PC60C	1	1085	47.0	29.4	15.25	20.50
				2	1550	55.0	36.7		11.50
TMLX100C20MP11	21.0	HD60	1	1255	48.5	32.0	15.50	21.00	
			2	1665	56.5	39.2		12.00	
TMLX100C20MP11	21.0	UC60C	1	1085	46.5	29.2	15.00	20.25	
			2	1550	55.0	36.5		11.50	
TMLX100C20MP11	21.0	UC60D	1	1105	46.5	29.6	15.25	20.50	
			2	1575	55.0	36.9		11.50	
TMLX120C20MP11	21.0	FC/MC/PC60D	1	1105	47.0	29.8	15.25	20.50	
			2	1575	55.5	36.9		11.50	
TMLX120C20MP11	21.0	FC/MC62D	1	1100	47.0	30.0	15.25	20.50	
			2	1575	56.0	37.7		11.50	

For Notes See Page 28.

COOLING CAPACITY - With High Efficiency Motor Furnaces (Continued)

UNIT MODEL	FURNACE		COIL MODEL ¹	COOLING					
	MODEL	WIDTH		STAGE	RATED CFM	NET MBH		SEER	EER
						TOTAL	SENS.		
18 SEER AC WITH HIGH EFFICIENCY MOTOR FURNACES²									
AL8B060F4C	TMLX120C20MP11	21.0	FC/PC60C	1	1085	47.0	29.4	15.25	20.50
				2	1550	55.0	36.7		11.50
	TMLX120C20MP11	21.0	HD60	1	1255	48.5	32.0	15.50	21.00
				2	1665	56.5	39.2		12.00
	TMLX120C20MP11	21.0	UC60C	1	1085	46.5	29.2	15.00	20.25
				2	1550	55.0	36.5		11.50
	TMLX120C20MP11	21.0	UC60D	1	1105	46.5	29.6	15.25	20.50
				2	1575	55.0	36.9		11.50
	TM9E100C20MP11	21.0	FC/MC/PC60D	1	960	45.5	28.0	15.00	20.25
				2	1525	54.5	36.3		11.25
	TM9E100C20MP11	21.0	FC/MC62D	1	985	46.0	28.8	15.25	20.25
				2	1550	55.5	37.5		11.50
	TM9E100C20MP11	21.0	FC64D	1	980	47.5	29.6	15.75	21.25
				2	1550	57.0	38.7		11.75
	TM9E100C20MP11	21.0	HD60	1	1220	48.5	32.0	15.50	20.75
				2	1625	56.5	39.2		12.00
	TM9E100C20MP11	21.0	UC60D	1	960	45.0	27.8	14.75	19.75
				2	1525	54.5	36.1		11.25
	TM9E120D20MP11	24.5	FC/MC/PC60D	1	980	46.0	28.4	15.00	20.50
				2	1550	55.0	36.7		11.50
	TM9E120D20MP11	24.5	FC/MC62D	1	980	45.5	28.6	15.25	20.25
				2	1550	55.5	37.5		11.50
	TM9E120D20MP11	24.5	FC64D	1	960	47.0	29.4	15.50	21.00
				2	1525	57.0	38.2		11.75
	TM9E120D20MP11	24.5	HD60	1	1240	48.5	32.0	15.50	21.00
				2	1645	56.5	38.7		11.75
	TM9E120D20MP11	24.5	UC60D	1	980	46.0	28.4	15.25	20.25
				2	1550	54.5	36.1		11.25
	TM9X100C20MP11	21.0	FC/MC/PC60D	1	960	45.5	28.0	15.00	20.25
				2	1525	54.5	36.3		11.25
	TM9X100C20MP11	21.0	FC/MC62D	1	985	46.0	28.8	15.25	20.25
				2	1550	55.5	37.5		11.50
	TM9X100C20MP11	21.0	FC64D	1	980	47.5	29.6	15.75	21.25
				2	1550	57.0	38.7		11.75
	TM9X100C20MP11	21.0	HD60	1	1220	48.5	32.0	15.50	20.75
				2	1625	56.5	39.2		12.00
	TM9X100C20MP11	21.0	UC60D	1	960	45.0	27.8	14.75	19.75
				2	1525	54.5	36.1		11.25
	TM9X120D20MP11	24.5	FC/MC/PC60D	1	980	46.0	28.4	15.00	20.50
				2	1550	55.0	36.7		11.50
TM9X120D20MP11	24.5	FC/MC62D	1	980	45.5	28.6	15.25	20.25	
			2	1550	55.5	37.5		11.50	
TM9X120D20MP11	24.5	FC64D	1	960	47.0	29.4	15.50	21.00	
			2	1525	57.0	38.2		11.75	
TM9X120D20MP11	24.5	HD60	1	1240	48.5	32.0	15.50	21.00	
			2	1645	56.5	38.7		11.75	
TM9X120D20MP11	24.5	UC60D	1	980	46.0	28.4	15.25	20.25	
			2	1550	54.5	36.1		11.25	
L*LC*C16	21.0	FC/PC60C	1	1025	46.0	28.6	14.75	20.00	
			2	1600	55.0	36.9		11.25	
L*LC*C20	21.0	FC/MC/PC60D	1	1060	46.5	29.2	15.00	20.25	
			2	1600	55.5	37.1		11.50	

For Notes See Page 28.

COOLING CAPACITY - With High Efficiency Motor Furnaces (Continued)

UNIT MODEL	FURNACE		COIL MODEL ¹	COOLING					
	MODEL	WIDTH		STAGE	RATED CFM	NET MBH		SEER	EER
						TOTAL	SENS.		
18 SEER AC WITH HIGH EFFICIENCY MOTOR FURNACES²									
AL8B060F4C	L*LC*C20	21.0	FC/MC62D	1	1015	46.0	29.0	14.75	19.75
				2	1600	56.0	38.2		11.50
	L*LC*C20	21.0	FC/PC60C	1	1060	46.5	29.2	15.00	20.25
				2	1600	55.5	37.1		11.50
	L*LC*C20	21.0	FC64D	1	1060	48.0	30.4	15.50	21.00
				2	1855	58.5	41.6		11.75
	L*LC*C20	21.0	HD60	1	1015	46.0	29.2	15.00	20.25
				2	1605	56.0	37.7		11.75
	L*LC*C20	21.0	UC60C	1	1015	45.5	28.4	15.00	20.00
				2	1605	55.5	37.3		11.50
	L*9C*C20	21.0	FC/MC/PC60D	1	1055	46.5	29.0	15.00	20.00
				2	1655	55.5	37.5		11.25
	L*9C*C20	21.0	FC/MC62D	1	1040	46.0	29.2	15.00	20.00
				2	1655	56.0	38.2		11.50
	L*9C*C20	21.0	FC/PC60C	1	1055	46.5	29.0	15.00	20.00
				2	1655	55.5	37.5		11.25
	L*9C*C20	21.0	FC64D	1	1040	48.0	30.2	15.50	20.75
				2	1655	57.5	39.7		11.75
	L*9C*C20	21.0	HD60	1	1055	46.5	29.8	15.00	20.00
				2	1655	55.5	38.2		11.50
	L*9C*C20	21.0	UC60C	1	1055	46.0	28.8	14.75	19.75
				2	1655	55.5	37.5		11.25
	L*9C*D20	24.5	FC/MC/PC60D	1	1070	46.5	29.2	15.00	20.00
				2	1615	55.5	37.1		11.50
	L*9C*D20	24.5	FC/MC62D	1	1085	47.0	29.8	15.00	20.00
				2	1630	56.0	38.2		11.50
	L*9C*D20	24.5	FC64D	1	1085	48.5	30.8	15.50	21.00
				2	1630	57.5	39.2		11.75
L*9C*D20	24.5	HD60	1	1070	46.5	29.8	15.00	20.00	
			2	1615	56.0	37.7		11.50	
L*9C*D20	24.5	UC60D	1	1070	46.0	29.0	14.75	19.75	
			2	1615	55.0	37.1		11.25	

1. MC coils available with a factory installed horizontal drain pan. See price pages for specific model number.

2. High Efficiency Motor Furnaces have B.O.D (Blower on Delay) standard.

PSC furnaces, such as the TG8S, TGLS, and TG9S, use Coil Only Ratings.

ACCESSORIES

Refer to Price Manual for specific model numbers.

Application Limits		
Maximum Lineset Equivalent Length	75 Ft	
Outdoor Ambient Temperature Limits		
Cooling Operation	Maximum DB	115°F
	Minimum DB	65°F

Long Lineset Applications - For installations with more than 75' of equivalent lineset length, refer to the current version of the **Piping Application Guide 247077-UAD-H-0209**, available in the Application Bulletins section on UPGnet.

Start Assist Kit (S1-2SA067*) - Provides increased starting torque for areas with low voltage. See Hard Start Kit Accessory Installation Manual for Hard Start Kit part number for each model.

TXV Kits - S1-1TVM series thermal expansion valves precisely meter refrigerant for optimum performance over a wide range of conditions. See System Charge table for TXV part number for each model.

Dehumidistat (S1-2HU16700124) - Provides increased dehumidification when matched with variable speed furnace or air handler.

Thermostats - Compatible thermostat controls are available through accessory sourcing. For optimum performance, these outdoor units are fully compatible with the Residential Touchscreen Communicating Control (Zoning and Non-Zoning versions). For more information, see the Residential Control Systems section of the Product Equipment Catalog.

SOUND POWER RATINGS

Stage 1	Octave Band Sound Power Level (db re. 1-pW)									
Model Number	63	125	250	500	1000	2000	4000	8000	dBA	SQI
AL8B024F4C	67	72	65	70	64	56	50	47	69	19.0
AL8B036F4C	69	70	64	72	64	57	53	49	71	19.0
AL8B048F4C	69	72	66	71	67	58	51	46	70	19.0
AL8B060F4C	69	74	69	72	67	61	56	50	72	19.0

Stage 2	Octave Band Sound Power Level (db re. 1-pW)									
Model Number	63	125	250	500	1000	2000	4000	8000	dBA	SQI
AL8B024F4C	67	72	66	70	64	57	52	49	70	19.0
AL8B036F4C	67	69	65	71	64	57	53	51	70	19.0
AL8B048F4C	69	74	66	67	65	57	51	47	69	19.0
AL8B060F4C	69	74	68	71	67	62	54	48	72	19.0

Rated in accordance with ARI Standard 270.

TYPICAL INSTALLATION

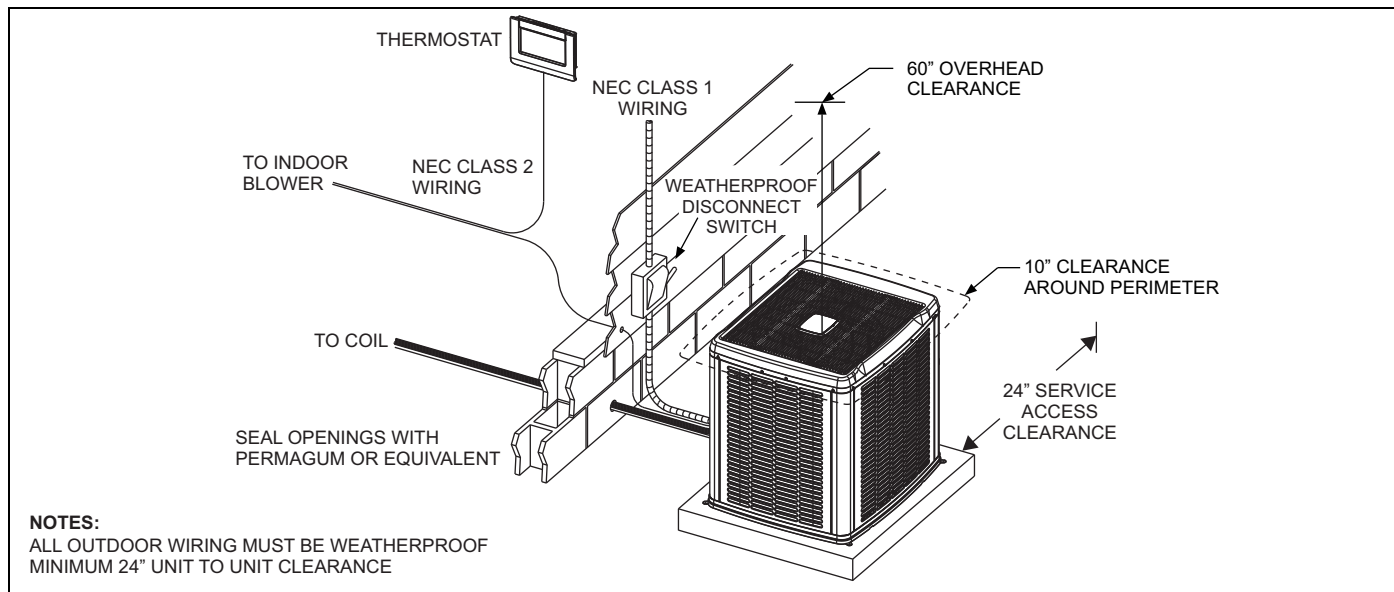

COOLING PERFORMANCE DATA - LOW CFM 1-STAGE OPERATION																
OUTDOOR UNIT MODEL NO.		AL8B024F4C														
INDOOR COIL MODEL NO.		FC48D + MV12D														
AIR TEMP. ENTERING OUTDOOR UNIT (°F)	ID CFM	550					600					650				
	ID DB (°F)	80	80	75	80	80	80	80	75	80	80	80	80	75	80	80
	ID WB (°F)	57	62	62	67	72	57	62	62	67	72	57	62	62	67	72
65	T.C.	18.4	19.4	19.5	20.8	23.6	19.2	19.8	20.0	21.4	24.1	19.9	20.1	20.5	21.9	24.6
	S.C.	17.4	17.1	14.3	13.9	11.5	18.1	17.8	15.1	14.7	12.2	18.8	18.5	15.9	15.5	12.9
	K.W.	0.79	0.80	0.79	0.77	0.74	0.77	0.79	0.78	0.77	0.73	0.75	0.78	0.78	0.76	0.72
75	T.C.	17.8	18.6	18.6	19.8	22.4	18.5	19.0	19.0	20.3	22.9	19.1	19.4	19.4	20.8	23.3
	S.C.	16.8	16.6	13.9	13.4	11.0	17.4	17.4	14.6	14.2	11.7	18.1	18.1	15.4	14.9	12.3
	K.W.	0.96	0.96	0.96	0.93	0.90	0.94	0.95	0.95	0.92	0.89	0.93	0.94	0.94	0.92	0.88
85	T.C.	17.3	17.8	17.7	18.8	21.1	17.8	18.3	18.1	19.3	21.6	18.4	18.7	18.4	19.7	22.1
	S.C.	16.2	16.2	13.5	13.0	10.6	16.7	16.9	14.2	13.6	11.1	17.3	17.6	14.8	14.3	11.7
	K.W.	1.13	1.11	1.12	1.10	1.06	1.11	1.10	1.11	1.08	1.05	1.10	1.10	1.10	1.07	1.04
95	T.C.	16.7	17.1	16.9	17.8	19.9	17.2	17.6	17.1	18.2	20.4	17.7	18.1	17.4	18.5	20.8
	S.C.	15.6	15.7	13.1	12.6	10.1	16.0	16.5	13.7	13.1	10.6	16.5	17.2	14.3	13.6	11.1
	K.W.	1.29	1.27	1.28	1.26	1.21	1.28	1.26	1.27	1.24	1.20	1.28	1.25	1.27	1.22	1.20
105	T.C.	15.8	16.1	15.7	16.8	18.7	16.2	16.6	16.0	17.2	19.1	16.7	17.0	16.2	17.5	19.5
	S.C.	14.7	14.9	12.6	12.3	9.8	15.1	15.5	13.2	12.8	10.3	15.6	16.1	13.8	13.4	10.8
	K.W.	1.50	1.48	1.49	1.47	1.43	1.49	1.47	1.48	1.45	1.42	1.49	1.46	1.48	1.44	1.41
115	T.C.	14.9	15.2	14.6	15.9	17.5	15.3	15.6	14.9	16.2	17.9	15.8	16.0	15.1	16.4	18.3
	S.C.	13.8	14.1	12.2	12.0	9.4	14.2	14.6	12.8	12.6	9.9	14.7	15.1	13.3	13.2	10.4
	K.W.	1.70	1.68	1.69	1.67	1.63	1.70	1.67	1.68	1.66	1.63	1.69	1.66	1.68	1.65	1.63
125	T.C.	14.0	14.2	13.5	14.9	16.4	14.4	14.6	13.8	15.2	16.7	14.8	15.0	14.0	15.4	17.1
	S.C.	12.9	13.2	11.7	11.7	9.1	13.3	13.6	12.3	12.3	9.6	13.7	14.0	12.9	13.0	10.1
	K.W.	1.90	1.88	1.89	1.87	1.84	1.90	1.87	1.89	1.86	1.84	1.90	1.86	1.89	1.86	1.84

NOTE: ALL CAPACITIES INCLUDE INDOOR FAN HEAT. KW VALUES ARE FOR THE SYSTEM (OUTDOOR + INDOOR).

Multipliers for determining the performance with other indoor sections.

NOTE: For dry bulb temperatures different than those listed (between 73-87 °F), sensible capacity increases by 1060 BTUH per 1000 CFM per degree above the listed temperature and decreases by 1060 BTUH per 1000 CFM per degree below the listed temperature.

LOW CFM

Air Handler	Coil	T.C.	S.C.	KW
-	FC/MC/PC48	0.97	0.96	1.20
AHE24B	-	0.95	0.92	1.02
AHE30B	-	0.95	0.92	1.02
AHV24B	-	0.93	0.87	1.01
AHV30B	-	0.95	0.92	1.01
AHV36C	-	0.95	0.90	1.01
MV12B	FC/MC35B	0.99	0.99	1.04
MV12B	FC/MC43B	0.99	1.00	1.04
MV12D	FC/MC48D	1.00	1.00	1.00
MX12BN21	FC/MC35B	0.98	0.96	1.01

Continued on next page.

Furnaces	Coil	T.C.	S.C.	KW
T*(8,L)V*A12	FC/MC/PC32A	0.97	0.96	1.04
T*(8,L)V*A12	FC/MC/PC37A	0.98	0.96	1.04
T*(8,L)V*A12	HD36	0.95	0.93	1.04
T*(8,L)V*B12	FC/MC/PC35B	0.94	0.91	1.04
T*(8,L)V*B12	FC/MC/PC43B	0.95	0.92	1.05
T*(8,L)V*B12	HD36	0.92	0.87	1.04
T*(8,L)V*C16	FC/MC/PC35C	0.97	0.96	1.04
T*(8,L)V*C16	FC/MC/PC43C	1.01	1.03	1.04
T*(8,L)V*C16	HD36	0.95	0.94	1.02
T*9V*A10	FC/MC/PC32A	0.97	0.96	1.07
T*9V*A10	FC/MC/PC37A	0.97	0.96	1.07
T*9V*B12	FC/MC/PC35B	0.96	0.94	1.03
T*9V*B12	FC/MC/PC43B	0.98	0.96	1.01
T*9V*B12	HD36	0.95	0.93	1.04
T*9V*C16	FC/MC/PC35C	1.00	1.02	1.03
T*9V*C16	FC/MC/PC48C	1.01	1.02	1.01
T*9V*C16	UC48C	0.99	1.01	1.02
T*9V*C20	FC/MC/PC43C	1.00	1.02	1.01
T*9V*C20	FC/MC/PC48C	1.01	1.02	1.01
T*9V*C20	UC48C	0.99	1.00	1.02
TM8X060A12MP11	HD36	0.95	0.93	1.06
TM8X080B12MP11	HD36	0.97	0.96	1.00
TM8X080C16MP11	FC/MC/PC35C	0.99	1.01	1.06
TM8X080C16MP11	FC/MC/PC43C	1.00	1.01	1.05
TM8X080C16MP11	FC/MC/PC48C	1.00	1.01	1.04
TM8X080C16MP11	HD36	0.98	1.00	1.01
TM8X080C16MP11	UC48C	0.99	0.99	1.06
TM8X100C16MP11	FC/MC/PC35C	0.99	1.01	1.06
TM8X100C16MP11	FC/MC/PC43C	1.00	1.01	1.05
TM8X100C16MP11	FC/MC/PC48C	1.00	1.01	1.04
TM8X100C16MP11	HD36	0.98	1.00	1.01
TM8X100C16MP11	UC48C	0.99	0.99	1.06
TMLX060A12MP11	HD36	0.95	0.93	1.06
TMLX080B12MP11	HD36	0.97	0.96	1.00
TMLX080C16MP11	FC/MC/PC35C	0.99	1.01	1.06
TMLX080C16MP11	FC/MC/PC43C	1.00	1.01	1.05
TMLX080C16MP11	FC/MC/PC48C	1.00	1.01	1.04

Furnaces	Coil	T.C.	S.C.	KW
TMLX080C16MP11	HD36	0.98	1.00	1.01
TMLX080C16MP11	UC48C	0.99	0.99	1.06
TMLX100C16MP11	FC/MC/PC35C	0.99	1.01	1.06
TMLX100C16MP11	FC/MC/PC43C	1.00	1.01	1.05
TMLX100C16MP11	FC/MC/PC48C	1.00	1.01	1.04
TMLX100C16MP11	HD36	0.98	1.00	1.01
TMLX100C16MP11	UC48C	0.99	0.99	1.06
TM9E040A10MP11	FC/MC/PC32A	0.97	0.96	1.05
TM9E060B12MP11	HD36	0.95	0.94	1.01
TM9E080B12MP11	HD36	0.95	0.94	1.01
TM9E080C16MP11	HD36	0.98	0.99	1.02
TM9E100C16MP11	HD36	0.98	0.99	1.02
TM9E100C20MP11	HD36	1.00	1.08	1.05
TM9X040A10MP11	FC/MC/PC32A	0.97	0.96	1.05
TM9X060B12MP11	HD36	0.95	0.94	1.01
TM9X080B12MP11	HD36	0.95	0.94	1.01
TM9X080C16MP11	HD36	0.98	0.99	1.02
TM9X100C16MP11	HD36	0.98	0.99	1.02
TM9X100C20MP11	HD36	1.00	1.08	1.05
L*LC*A12	FC/MC/PC32A	0.97	0.96	1.04
L*LC*A12	FC/MC/PC37A	0.98	0.96	1.04
L*LC*A12	HD36	0.95	0.93	1.04
L*LC*B12	FC/MC/PC35B	0.94	0.91	1.04
L*LC*B12	FC/MC/PC43B	0.95	0.92	1.05
L*LC*B12	HD36	0.92	0.87	1.04
L*LC*C16	FC/MC/PC35C	0.97	0.96	1.04
L*LC*C16	FC/MC/PC43C	1.01	1.03	1.04
L*LC*C16	HD36	0.95	0.94	1.02
L*9C*B12	FC/MC/PC35B	0.96	0.94	1.03
L*9C*B12	FC/MC/PC43B	0.98	0.96	1.01
L*9C*B12	HD36	0.95	0.93	1.04
L*9C*C16	FC/MC/PC35C	1.00	1.02	1.03
L*9C*C16	FC/MC/PC48C	1.01	1.02	1.01
L*9C*C16	UC48C	0.99	1.01	1.02
L*9C*C20	FC/MC/PC43C	1.00	1.02	1.01
L*9C*C20	FC/MC/PC48C	1.01	1.02	1.01
L*9C*C20	UC48C	0.99	1.00	1.02

COOLING PERFORMANCE DATA - HIGH CFM 2-STAGE OPERATION																
OUTDOOR UNIT MODEL NO.		AL8B024F4C														
INDOOR COIL MODEL NO.		FC48D + MV12D														
AIR TEMP. ENTERING OUTDOOR UNIT (°F)	ID CFM	800					900					1000				
	ID DB (°F)	80	80	75	80	80	80	80	75	80	80	80	80	75	80	80
	ID WB (°F)	57	62	62	67	72	57	62	62	67	72	57	62	62	67	72
65	T.C.	23.4	25.0	25.3	26.9	30.3	24.9	25.6	25.8	27.6	30.8	26.3	26.2	26.4	28.2	31.4
	S.C.	21.9	21.2	18.5	17.4	15.0	23.1	22.4	19.3	18.7	15.6	24.4	23.6	20.1	20.1	16.3
	K.W.	1.16	1.14	1.14	1.16	1.18	1.15	1.14	1.13	1.16	1.17	1.14	1.16	1.13	1.17	1.17
75	T.C.	22.8	24.0	24.0	25.7	28.8	24.1	24.7	24.6	26.4	29.4	25.4	25.3	25.1	27.1	30.0
	S.C.	21.1	20.6	17.8	16.9	14.2	22.2	21.7	18.7	18.3	14.9	23.3	22.8	19.5	19.5	15.6
	K.W.	1.32	1.32	1.32	1.33	1.35	1.31	1.32	1.31	1.33	1.35	1.31	1.32	1.31	1.33	1.35
85	T.C.	22.2	23.0	22.8	24.5	27.3	23.4	23.7	23.4	25.2	27.9	24.5	24.4	23.9	25.9	28.6
	S.C.	20.4	20.0	17.1	16.5	13.5	21.3	21.0	18.1	17.8	14.2	22.3	22.1	19.0	19.0	15.0
	K.W.	1.47	1.50	1.50	1.50	1.53	1.47	1.49	1.49	1.49	1.52	1.48	1.49	1.49	1.50	1.52
95	T.C.	21.7	22.0	21.6	23.3	25.8	22.6	22.8	22.1	24.0	26.5	23.6	23.5	22.7	24.7	27.1
	S.C.	19.6	19.4	16.4	16.1	12.7	20.4	20.4	17.4	17.3	13.5	21.2	21.3	18.4	18.5	14.3
	K.W.	1.63	1.68	1.68	1.66	1.70	1.63	1.66	1.67	1.66	1.69	1.64	1.66	1.67	1.66	1.69
105	T.C.	20.9	21.1	20.5	22.2	24.5	21.8	21.8	21.1	22.8	25.1	22.8	22.6	21.6	23.3	25.8
	S.C.	18.9	19.0	16.2	15.9	12.4	19.7	19.8	17.2	17.1	13.3	20.5	20.6	18.2	18.2	14.1
	K.W.	1.90	1.94	1.93	1.93	1.95	1.90	1.92	1.92	1.92	1.95	1.92	1.92	1.93	1.92	1.95
115	T.C.	20.1	20.1	19.5	21.2	23.3	21.1	20.9	20.1	21.6	23.9	22.0	21.7	20.6	22.1	24.5
	S.C.	18.2	18.5	15.9	15.7	12.2	19.0	19.2	17.0	16.9	13.0	19.8	19.8	18.1	18.0	13.8
	K.W.	2.17	2.19	2.18	2.18	2.20	2.17	2.18	2.17	2.18	2.20	2.18	2.17	2.18	2.18	2.20
125	T.C.	19.4	19.2	18.5	20.1	22.0	20.3	20.0	19.0	20.4	22.6	21.2	20.8	19.6	20.8	23.1
	S.C.	17.5	18.1	15.7	15.5	11.9	18.3	18.6	16.8	16.7	12.8	19.1	19.1	17.9	17.8	13.6
	K.W.	2.44	2.45	2.42	2.44	2.45	2.43	2.43	2.42	2.43	2.45	2.44	2.43	2.43	2.44	2.45

NOTE: ALL CAPACITIES INCLUDE INDOOR FAN HEAT. KW VALUES ARE FOR THE SYSTEM (OUTDOOR + INDOOR).

Multipliers for determining the performance with other indoor sections.

NOTE: For dry bulb temperatures different than those listed (between 73-87 °F), sensible capacity increases by 1060 BTUH per 1000 CFM per degree above the listed temperature and decreases by 1060 BTUH per 1000 CFM per degree below the listed temperature.

HIGH CFM

Air Handlers	Coils	T.C.	S.C.	KW
-	FC/MC/PC48	0.96	0.91	1.13
AHE24B	-	0.96	0.92	1.03
AHE30B	-	0.96	0.92	1.03
AHV24B	-	0.94	0.87	1.01
AHV30B	-	0.96	0.92	1.03
AHV36C	-	0.97	0.92	1.02
MV12B	FC/MC35B	0.96	0.93	1.01
MV12B	FC/MC43B	0.98	0.95	1.03
MV12D	FC/MC48D	1.00	1.00	1.00
MX12BN21	FC/MC35B	0.95	0.91	1.02

Continued on next page.

Furnaces	Coils	T.C.	S.C.	KW
T*(8,L)V*A12	FC/MC/PC32A	0.95	0.91	1.02
T*(8,L)V*A12	FC/MC/PC37A	0.97	0.93	1.02
T*(8,L)V*A12	HD36	0.94	0.89	1.03
T*(8,L)V*B12	FC/MC/PC35B	0.96	0.91	1.03
T*(8,L)V*B12	FC/MC/PC43B	0.97	0.94	1.02
T*(8,L)V*B12	HD36	0.93	0.86	1.02
T*(8,L)V*C16	FC/MC/PC35C	0.96	0.91	1.01
T*(8,L)V*C16	FC/MC/PC43C	0.97	0.93	1.00
T*(8,L)V*C16	HD36	0.95	0.89	1.02
T*9V*A10	FC/MC/PC32A	0.94	0.90	1.07
T*9V*A10	FC/MC/PC37A	0.96	0.92	1.07
T*9V*B12	FC/MC/PC35B	0.96	0.93	1.03
T*9V*B12	FC/MC/PC43B	0.97	0.93	1.04
T*9V*B12	HD36	0.95	0.89	1.02
T*9V*C16	FC/MC/PC35C	0.98	0.98	1.05
T*9V*C16	FC/MC/PC48C	0.99	1.00	1.03
T*9V*C16	UC48C	0.98	0.98	1.03
T*9V*C20	FC/MC/PC43C	0.99	0.99	1.03
T*9V*C20	FC/MC/PC48C	0.99	1.00	1.03
T*9V*C20	UC48C	0.98	0.98	1.03
TM8X060A12MP11	HD36	0.95	0.89	1.02
TM8X080B12MP11	HD36	0.97	0.92	1.00
TM8X080C16MP11	FC/MC/PC35C	0.95	0.91	1.06
TM8X080C16MP11	FC/MC/PC43C	0.96	0.93	1.07
TM8X080C16MP11	FC/MC/PC48C	0.97	0.93	1.06
TM8X080C16MP11	HD36	0.97	0.92	1.00
TM8X080C16MP11	UC48C	0.95	0.91	1.06
TM8X100C16MP11	FC/MC/PC35C	0.95	0.91	1.06
TM8X100C16MP11	FC/MC/PC43C	0.96	0.93	1.07
TM8X100C16MP11	FC/MC/PC48C	0.97	0.93	1.06
TM8X100C16MP11	HD36	0.97	0.92	1.00
TM8X100C16MP11	UC48C	0.95	0.91	1.06
TMLX060A12MP11	HD36	0.95	0.89	1.02
TMLX080B12MP11	HD36	0.97	0.92	1.00
TMLX080C16MP11	FC/MC/PC35C	0.95	0.91	1.06
TMLX080C16MP11	FC/MC/PC43C	0.96	0.93	1.07
TMLX080C16MP11	FC/MC/PC48C	0.97	0.93	1.06

Furnaces	Coils	T.C.	S.C.	KW
TMLX080C16MP11	HD36	0.97	0.92	1.00
TMLX080C16MP11	UC48C	0.95	0.91	1.06
TMLX100C16MP11	FC/MC/PC35C	0.95	0.91	1.06
TMLX100C16MP11	FC/MC/PC43C	0.96	0.93	1.07
TMLX100C16MP11	FC/MC/PC48C	0.97	0.93	1.06
TMLX100C16MP11	HD36	0.97	0.92	1.00
TMLX100C16MP11	UC48C	0.95	0.91	1.06
TM9E040A10MP11	FC/MC/PC32A	0.93	0.90	1.08
TM9E060B12MP11	HD36	0.95	0.89	1.00
TM9E080B12MP11	HD36	0.95	0.89	1.00
TM9E080C16MP11	HD36	0.93	0.86	0.98
TM9E100C16MP11	HD36	0.93	0.86	0.98
TM9E100C20MP11	HD36	0.96	0.90	1.01
TM9X040A10MP11	FC/MC/PC32A	0.93	0.90	1.08
TM9X060B12MP11	HD36	0.95	0.89	1.00
TM9X080B12MP11	HD36	0.95	0.89	1.00
TM9X080C16MP11	HD36	0.93	0.86	0.98
TM9X100C16MP11	HD36	0.93	0.86	0.98
TM9X100C20MP11	HD36	0.96	0.90	1.01
L*LC*A12	FC/MC/PC32A	0.95	0.91	1.02
L*LC*A12	FC/MC/PC37A	0.97	0.93	1.02
L*LC*A12	HD36	0.94	0.89	1.03
L*LC*B12	FC/MC/PC35B	0.96	0.91	1.03
L*LC*B12	FC/MC/PC43B	0.97	0.94	1.02
L*LC*B12	HD36	0.93	0.86	1.02
L*LC*C16	FC/MC/PC35C	0.96	0.91	1.01
L*LC*C16	FC/MC/PC43C	0.97	0.93	1.00
L*LC*C16	HD36	0.95	0.89	1.02
L*9C*B12	FC/MC/PC35B	0.96	0.93	1.03
L*9C*B12	FC/MC/PC43B	0.97	0.93	1.04
L*9C*B12	HD36	0.95	0.89	1.02
L*9C*C16	FC/MC/PC35C	0.98	0.98	1.05
L*9C*C16	FC/MC/PC48C	0.99	1.00	1.03
L*9C*C16	UC48C	0.98	0.98	1.03
L*9C*C20	FC/MC/PC43C	0.99	0.99	1.03
L*9C*C20	FC/MC/PC48C	0.99	1.00	1.03
L*9C*C20	UC48C	0.98	0.98	1.03

COOLING PERFORMANCE DATA - LOW CFM 1-STAGE OPERATION																
OUTDOOR UNIT MODEL NO.		AL8B036F4C														
INDOOR COIL MODEL NO.		FC62D + MV12D														
AIR TEMP. ENTERING OUTDOOR UNIT (°F)	ID CFM	750					800					850				
	ID DB (°F)	80	80	75	80	80	80	80	75	80	80	80	80	75	80	80
	ID WB (°F)	57	62	62	67	72	57	62	62	67	72	57	62	62	67	72
65	T.C.	28.0	27.0	26.8	29.7	31.9	28.8	27.3	26.9	30.2	32.5	29.7	27.7	27.0	30.6	33.0
	S.C.	23.7	22.9	19.3	19.4	15.5	24.4	23.6	19.8	19.9	16.0	25.2	24.3	20.4	20.4	16.4
	K.W.	1.06	1.07	1.04	1.05	1.03	1.05	1.06	1.04	1.03	1.02	1.04	1.04	1.04	1.02	1.01
75	T.C.	26.4	25.7	25.6	28.4	30.8	27.2	26.1	25.9	28.8	31.3	28.0	26.5	26.1	29.3	31.8
	S.C.	22.8	21.9	18.6	18.8	15.0	23.5	22.7	19.2	19.4	15.5	24.2	23.5	19.8	19.9	16.0
	K.W.	1.30	1.30	1.29	1.28	1.26	1.29	1.29	1.29	1.27	1.24	1.28	1.28	1.28	1.26	1.23
85	T.C.	24.7	24.4	24.5	27.1	29.6	25.6	24.9	24.8	27.5	30.1	26.4	25.3	25.2	27.9	30.6
	S.C.	21.8	20.9	17.9	18.3	14.5	22.5	21.8	18.5	18.9	15.0	23.2	22.6	19.2	19.4	15.5
	K.W.	1.55	1.54	1.54	1.51	1.48	1.53	1.53	1.53	1.50	1.47	1.52	1.52	1.52	1.49	1.45
95	T.C.	23.1	23.1	23.3	25.8	28.5	23.9	23.7	23.8	26.2	28.9	24.8	24.2	24.3	26.6	29.4
	S.C.	20.9	20.0	17.2	17.7	14.0	21.6	20.8	17.9	18.3	14.5	22.2	21.7	18.6	19.0	15.0
	K.W.	1.79	1.78	1.79	1.74	1.71	1.77	1.76	1.78	1.74	1.69	1.75	1.75	1.77	1.73	1.67
105	T.C.	22.2	22.2	22.0	24.3	26.9	22.9	22.7	22.4	24.6	27.3	23.7	23.2	22.9	25.0	27.7
	S.C.	19.9	19.2	16.6	17.1	13.5	20.5	19.9	17.3	17.7	14.0	21.1	20.7	17.9	18.3	14.6
	K.W.	2.11	2.10	2.11	2.07	2.04	2.09	2.09	2.10	2.06	2.03	2.08	2.08	2.09	2.06	2.02
115	T.C.	21.2	21.2	20.7	22.8	25.3	21.9	21.8	21.1	23.1	25.6	22.6	22.3	21.5	23.4	26.0
	S.C.	19.0	18.4	16.1	16.5	13.0	19.5	19.1	16.7	17.1	13.5	20.0	19.7	17.3	17.6	14.1
	K.W.	2.42	2.42	2.42	2.38	2.37	2.40	2.40	2.41	2.38	2.36	2.39	2.39	2.40	2.37	2.35
125	T.C.	20.3	20.3	19.4	21.3	23.7	20.9	20.9	19.7	21.5	24.0	21.5	21.4	20.1	21.8	24.3
	S.C.	18.0	17.6	15.7	15.8	12.5	18.5	18.2	16.1	16.4	13.1	19.0	18.8	16.6	17.0	13.6
	K.W.	2.73	2.73	2.73	2.70	2.70	2.72	2.72	2.72	2.69	2.69	2.70	2.70	2.71	2.69	2.69

NOTE: ALL CAPACITIES INCLUDE INDOOR FAN HEAT. KW VALUES ARE FOR THE SYSTEM (OUTDOOR + INDOOR).

Multipliers for determining the performance with other indoor sections.

NOTE: For dry bulb temperatures different than those listed (between 73-87 °F), sensible capacity increases by 1060 BTUH per 1000 CFM per degree above the listed temperature and decreases by 1060 BTUH per 1000 CFM per degree below the listed temperature.

LOW CFM

Air Handlers	Coils	T.C.	S.C.	KW
-	FC/MC62	0.99	1.01	1.23
AHE36C	-	1.00	1.02	1.05
AHE42D	-	0.97	0.93	1.03
AHV36C	-	0.99	0.98	1.02
AHV42D	-	1.00	0.99	1.00
AHV48D	-	1.01	1.02	1.01
MV12B	FC/MC35B	0.97	0.95	1.07
MV12B	FC/MC43B	0.99	0.99	1.05
MV12D	FC/MC48D	1.00	0.99	1.02
MV12D	FC/MC60D	0.98	0.95	1.03
MV12D	FC/MC62D	1.00	1.00	1.00
MV12D	FC64D	1.02	1.02	1.00
MV16C	FC/MC35C	0.97	0.96	1.04

Air Handlers	Coils	T.C.	S.C.	KW
MV16C	FC/MC43C	0.98	0.97	1.06
MV16C	FC/MC48C	0.99	0.99	1.05
MV20D	FC/MC48D	1.01	1.03	1.03
MV20D	FC/MC60D	1.01	1.03	1.03
MV20D	FC/MC62D	1.01	1.03	1.03
MV20D	FC64D	1.04	1.07	1.02
MX12BN21	FC/MC35B	0.97	0.95	1.02
MX12BN21	FC/MC43B	0.99	0.97	1.01
MX12DN21	FC/MC48D	1.01	1.02	1.02
MX12DN21	FC/MC60D	1.01	1.02	1.02
MX12DN21	FC64D	1.05	1.08	1.01

Continued on next page.

Furnaces	Coils	T.C.	S.C.	KW
T*(8,L)V*A12	FC/MC/PC37A	0.97	0.94	1.09
T*(8,L)V*B12	FC/MC/PC35B	0.97	0.95	1.08
T*(8,L)V*B12	FC/MC/PC43B	1.00	1.02	1.10
T*(8,L)V*B12	HD48	0.98	0.95	1.04
T*(8,L)V*C16	FC/MC/PC35C	0.97	0.95	1.07
T*(8,L)V*C16	FC/MC/PC43C	0.98	0.97	1.06
T*(8,L)V*C16	FC/MC/PC48C	0.98	0.95	1.06
T*(8,L)V*C16	FC/PC60C	0.98	0.95	1.06
T*(8,L)V*C16	HD48	1.00	0.99	1.04
T*(8,L)V*C16	UC48C	0.97	0.97	1.05
T*(8,L)V*C16	UC60C	0.99	0.98	1.04
T*(8,L)V*C20	FC/MC/PC35C	1.01	1.08	1.09
T*(8,L)V*C20	FC/MC/PC43C	0.97	0.95	1.05
T*(8,L)V*C20	FC/MC/PC48C	0.97	0.94	1.04
T*(8,L)V*C20	FC/PC60C	0.99	0.99	1.04
T*(8,L)V*C20	HD48	0.97	0.94	1.03
T*(8,L)V*C20	UC48C	0.94	0.92	1.05
T*(8,L)V*C20	UC60C	0.99	0.98	1.04
T*9V*B12	FC/MC/PC35B	0.97	0.95	1.09
T*9V*B12	FC/MC/PC43B	0.99	1.00	1.08
T*9V*B12	HD48	0.97	0.93	1.05
T*9V*C16	FC/MC/PC35C	0.97	0.95	1.06
T*9V*C16	FC/MC/PC43C	0.99	1.00	1.07
T*9V*C16	FC/MC/PC48C	0.99	0.99	1.05
T*9V*C16	FC/PC60C	0.99	0.99	1.06
T*9V*C16	HD48	0.99	0.97	1.04
T*9V*C16	UC48C	0.95	0.94	1.06
T*9V*C16	UC60C	0.99	0.99	1.06
T*9V*C20	FC/MC/PC35C	0.97	0.95	1.07
T*9V*C20	FC/MC/PC43C	0.99	0.98	1.05
T*9V*C20	FC/MC/PC48C	0.98	0.96	1.04
T*9V*C20	FC/PC60C	0.99	0.97	1.04
T*9V*C20	HD48	0.98	0.95	1.04
T*9V*C20	UC48C	0.95	0.93	1.06
T*9V*C20	UC60C	0.98	0.97	1.04
T*9V*D20	FC/MC/PC48D	1.01	1.01	1.05
T*9V*D20	FC/MC/PC60D	1.00	1.01	1.04
T*9V*D20	FC/MC62D	1.01	1.02	1.05
T*9V*D20	FC64D	1.03	1.05	1.03
T*9V*D20	HD48	1.00	1.00	1.04
T*9V*D20	UC48D	0.97	0.98	1.06
T*9V*D20	UC60D	0.99	1.00	1.05
TM8X060A12MP11	FC/MC/PC37A	0.99	0.97	1.05
TM8X080B12MP11	FC/MC/PC35B	0.97	0.95	1.06
TM8X080B12MP11	FC/MC/PC43B	0.99	0.97	1.05
TM8X080B12MP11	HD48	1.01	1.01	1.02
TM8X080C16MP11	FC/MC/PC35C	0.97	0.96	1.03
TM8X080C16MP11	FC/MC/PC43C	0.99	0.97	1.02
TM8X080C16MP11	FC/MC/PC48C	1.00	0.99	1.01
TM8X080C16MP11	FC/MC/PC48D	1.00	0.99	1.02
TM8X080C16MP11	FC/MC/PC60D	1.00	1.00	1.01
TM8X080C16MP11	FC/MC62D	0.99	0.99	1.01
TM8X080C16MP11	FC/PC60C	0.99	0.99	1.01
TM8X080C16MP11	FC64D	1.02	1.02	1.00
TM8X080C16MP11	HD48	0.95	0.90	1.02
TM8X080C16MP11	UC48C	0.96	0.94	1.03
TM8X080C16MP11	UC48D	0.96	0.94	1.03
TM8X080C16MP11	UC60C	0.99	0.98	1.02
TM8X080C16MP11	UC60D	0.99	0.98	1.02
TM8X080C16MP11	FC/MC/PC35C	0.97	0.96	1.03
TM8X080C16MP11	FC/MC/PC43C	0.99	0.97	1.02
TM8X080C16MP11	FC/MC/PC48C	1.00	0.99	1.01
TM8X080C16MP11	FC/MC/PC48D	1.00	0.99	1.02
TM8X080C16MP11	FC/MC/PC60D	1.00	1.00	1.01
TM8X080C16MP11	FC/MC62D	0.99	0.99	1.01
TM8X080C16MP11	FC/PC60C	0.99	0.99	1.01
TM8X080C16MP11	FC64D	1.02	1.02	1.00
TM8X080C16MP11	HD48	0.95	0.90	1.02
TM8X080C16MP11	UC48C	0.96	0.94	1.03

Furnaces	Coils	T.C.	S.C.	KW
TM8X080C16MP11	UC48D	0.96	0.94	1.03
TM8X080C16MP11	UC60C	0.99	0.98	1.02
TM8X080C16MP11	UC60D	0.99	0.98	1.02
TM8X100C16MP11	FC/MC/PC35C	0.97	0.96	1.03
TM8X100C16MP11	FC/MC/PC43C	0.99	0.97	1.02
TM8X100C16MP11	FC/MC/PC48C	1.00	0.99	1.01
TM8X100C16MP11	FC/MC/PC48D	1.00	0.99	1.02
TM8X100C16MP11	FC/MC/PC60D	1.00	1.00	1.01
TM8X100C16MP11	FC/MC62D	0.99	0.99	1.01
TM8X100C16MP11	FC/PC60C	0.99	0.99	1.01
TM8X100C16MP11	FC64D	1.02	1.02	1.00
TM8X100C16MP11	HD48	0.95	0.90	1.02
TM8X100C16MP11	UC48C	0.96	0.94	1.03
TM8X100C16MP11	UC48D	0.96	0.94	1.03
TM8X100C16MP11	UC60C	0.99	0.98	1.02
TM8X100C16MP11	UC60D	0.99	0.98	1.02
TM8X100C20MP11	HD48	1.01	1.00	1.03
TM8X120C20MP11	HD48	1.01	1.00	1.03
TMLX060A12MP11	FC/MC/PC37A	0.99	0.97	1.05
TMLX080B12MP11	FC/MC/PC35B	0.97	0.95	1.06
TMLX080B12MP11	FC/MC/PC43B	0.99	0.97	1.05
TMLX080B12MP11	HD48	1.01	1.01	1.02
TMLX080C16MP11	FC/MC/PC35C	0.97	0.96	1.03
TMLX080C16MP11	FC/MC/PC43C	0.99	0.97	1.02
TMLX080C16MP11	FC/MC/PC48C	1.00	0.99	1.01
TMLX080C16MP11	FC/MC/PC48D	1.00	0.99	1.02
TMLX080C16MP11	FC/MC/PC60D	1.00	1.00	1.01
TMLX080C16MP11	FC/MC62D	0.99	0.99	1.01
TMLX080C16MP11	FC/PC60C	0.99	0.99	1.01
TMLX080C16MP11	FC64D	1.02	1.02	1.00
TMLX080C16MP11	HD48	0.95	0.90	1.02
TMLX080C16MP11	UC48C	0.96	0.94	1.03
TMLX080C16MP11	UC48D	0.96	0.94	1.03
TMLX080C16MP11	UC60C	0.99	0.98	1.02
TMLX080C16MP11	UC60D	0.99	0.98	1.02
TMLX100C16MP11	FC/MC/PC35C	0.97	0.96	1.03
TMLX100C16MP11	FC/MC/PC43C	0.99	0.97	1.02
TMLX100C16MP11	FC/MC/PC48C	1.00	0.99	1.01
TMLX100C16MP11	FC/MC/PC48D	1.00	0.99	1.02
TMLX100C16MP11	FC/MC/PC60D	1.00	1.00	1.01
TMLX100C16MP11	FC/MC62D	0.99	0.99	1.01
TMLX100C16MP11	FC/PC60C	0.99	0.99	1.01
TMLX100C16MP11	FC64D	1.02	1.02	1.00
TMLX100C16MP11	HD48	0.95	0.90	1.02
TMLX100C16MP11	UC48C	0.96	0.94	1.03
TMLX100C16MP11	UC48D	0.96	0.94	1.03
TMLX100C16MP11	UC60C	0.99	0.98	1.02
TMLX100C16MP11	UC60D	0.99	0.98	1.02
TMLX100C20MP11	HD48	1.01	1.00	1.03
TMLX120C20MP11	HD48	1.01	1.00	1.03
TM9E060B12MP11	FC/MC/PC35B	0.96	0.94	1.05
TM9E060B12MP11	FC/MC/PC43B	0.97	0.95	1.04
TM9E060B12MP11	HD48	0.99	0.96	1.03
TM9E080B12MP11	FC/MC/PC35B	0.96	0.94	1.05
TM9E080B12MP11	FC/MC/PC43B	0.97	0.95	1.04

Continued on next page.

Furnaces	Coils	T.C.	S.C.	KW
TM9E080B12MP11	HD48	0.99	0.96	1.03
TM9E080C16MP11	FC/MC/PC48D	0.99	0.99	1.02
TM9E080C16MP11	FC/MC62D	0.98	0.97	1.02
TM9E080C16MP11	FC64D	1.02	1.02	1.01
TM9E080C16MP11	HD48	0.96	0.91	1.01
TM9E080C16MP11	UC48D	0.96	0.94	1.05
TM9E100C16MP11	FC/MC/PC48D	0.99	0.99	1.02
TM9E100C16MP11	FC/MC62D	0.98	0.97	1.02
TM9E100C16MP11	FC64D	1.02	1.02	1.01
TM9E100C16MP11	HD48	0.96	0.91	1.01
TM9E100C16MP11	UC48D	0.96	0.94	1.05
TM9E100C20MP11	HD48	1.00	0.99	1.03
TM9E120D20MP11	HD48	1.00	1.01	1.02
TM9X060B12MP11	FC/MC/PC35B	0.96	0.94	1.05
TM9X060B12MP11	FC/MC/PC43B	0.97	0.95	1.04
TM9X060B12MP11	HD48	0.99	0.96	1.03
TM9X080B12MP11	FC/MC/PC35B	0.96	0.94	1.05
TM9X080B12MP11	FC/MC/PC43B	0.97	0.95	1.04
TM9X080B12MP11	HD48	0.99	0.96	1.03
TM9X080C16MP11	FC/MC/PC48D	0.99	0.99	1.02
TM9X080C16MP11	FC/MC62D	0.98	0.97	1.02
TM9X080C16MP11	FC64D	1.02	1.02	1.01
TM9X080C16MP11	HD48	0.96	0.91	1.01
TM9X080C16MP11	UC48D	0.96	0.94	1.05
TM9X100C16MP11	FC/MC/PC48D	0.99	0.99	1.02
TM9X100C16MP11	FC/MC62D	0.98	0.97	1.02
TM9X100C16MP11	FC64D	1.02	1.02	1.01
TM9X100C16MP11	HD48	0.96	0.91	1.01
TM9X100C16MP11	UC48D	0.96	0.94	1.05
TM9X100C20MP11	HD48	1.00	0.99	1.03
TM9X120D20MP11	HD48	1.00	1.01	1.02
L*LC*A12	FC/MC/PC37A	0.97	0.94	1.09
L*LC*B12	FC/MC/PC35B	0.97	0.95	1.08
L*LC*B12	FC/MC/PC43B	1.00	1.02	1.10
L*LC*B12	HD48	0.98	0.95	1.04
L*LC*C16	FC/MC/PC35C	0.97	0.95	1.07
L*LC*C16	FC/MC/PC43C	0.98	0.97	1.06
L*LC*C16	FC/MC/PC48C	0.98	0.95	1.06

Furnaces	Coils	T.C.	S.C.	KW
L*LC*C16	FC/PC60C	0.98	0.95	1.06
L*LC*C16	HD48	1.00	0.99	1.04
L*LC*C16	UC48C	0.97	0.97	1.05
L*LC*C16	UC60C	0.99	0.98	1.04
L*LC*C20	FC/MC/PC35C	1.01	1.08	1.09
L*LC*C20	FC/MC/PC43C	0.97	0.95	1.05
L*LC*C20	FC/MC/PC48C	0.97	0.94	1.04
L*LC*C20	FC/PC60C	0.99	0.99	1.04
L*LC*C20	HD48	0.97	0.94	1.03
L*LC*C20	UC48C	0.94	0.92	1.05
L*LC*C20	UC60C	0.99	0.98	1.04
L*9C*B12	FC/MC/PC35B	0.97	0.95	1.09
L*9C*B12	FC/MC/PC43B	0.99	1.00	1.08
L*9C*B12	HD48	0.97	0.93	1.05
L*9C*C16	FC/MC/PC35C	0.97	0.95	1.06
L*9C*C16	FC/MC/PC43C	0.99	1.00	1.07
L*9C*C16	FC/MC/PC48C	0.99	0.99	1.05
L*9C*C16	FC/PC60C	0.99	0.99	1.06
L*9C*C16	HD48	0.99	0.97	1.04
L*9C*C16	UC48C	0.95	0.94	1.06
L*9C*C16	UC60C	0.99	0.99	1.06
L*9C*C20	FC/MC/PC35C	0.97	0.95	1.07
L*9C*C20	FC/MC/PC43C	0.99	0.98	1.05
L*9C*C20	FC/MC/PC48C	0.98	0.96	1.04
L*9C*C20	FC/PC60C	0.99	0.97	1.04
L*9C*C20	HD48	0.98	0.95	1.04
L*9C*C20	UC48C	0.95	0.93	1.06
L*9C*C20	UC60C	0.98	0.97	1.04
L*9C*D20	FC/MC/PC48D	1.01	1.01	1.05
L*9C*D20	FC/MC/PC60D	1.00	1.01	1.04
L*9C*D20	FC/MC62D	1.01	1.02	1.05
L*9C*D20	FC64D	1.03	1.05	1.03
L*9C*D20	HD48	1.00	1.00	1.04
L*9C*D20	UC48D	0.97	0.98	1.06
L*9C*D20	UC60D	0.99	1.00	1.05

COOLING PERFORMANCE DATA - HIGH CFM 2-STAGE OPERATION																
OUTDOOR UNIT MODEL NO.		AL8B036F4C														
INDOOR COIL MODEL NO.		FC62D + MV12D														
AIR TEMP. ENTERING OUTDOOR UNIT (°F)	ID CFM	1125					1225					1325				
	ID DB (°F)	80	80	75	80	80	80	80	75	80	80	80	80	75	80	80
	ID WB (°F)	57	62	62	67	72	57	62	62	67	72	57	62	62	67	72
65	T.C.	38.6	36.6	36.0	40.4	43.2	40.0	37.4	36.6	41.1	43.9	41.3	38.2	37.3	41.9	44.7
	S.C.	33.3	31.1	26.4	26.4	20.9	34.5	32.3	27.7	27.6	21.6	35.7	33.5	29.0	28.7	22.2
	K.W.	1.65	1.67	1.67	1.69	1.71	1.67	1.68	1.68	1.70	1.73	1.70	1.70	1.70	1.72	1.75
75	T.C.	36.8	35.4	35.0	38.7	41.7	38.1	36.1	35.6	39.4	42.4	39.3	36.8	36.2	40.1	43.1
	S.C.	32.2	30.5	25.9	25.8	20.3	33.2	31.7	27.1	26.9	21.0	34.3	32.8	28.3	28.0	21.7
	K.W.	1.90	1.91	1.91	1.93	1.96	1.91	1.92	1.92	1.94	1.98	1.94	1.94	1.94	1.96	2.00
85	T.C.	35.0	34.1	34.0	37.0	40.1	36.2	34.8	34.6	37.7	40.8	37.3	35.4	35.2	38.4	41.5
	S.C.	31.0	30.0	25.4	25.1	19.8	32.0	31.1	26.6	26.2	20.5	32.9	32.2	27.6	27.4	21.2
	K.W.	2.14	2.15	2.15	2.18	2.22	2.16	2.16	2.16	2.19	2.22	2.19	2.18	2.18	2.21	2.24
95	T.C.	33.2	32.9	33.1	35.4	38.6	34.2	33.5	33.6	36.0	39.2	35.2	34.0	34.2	36.6	39.8
	S.C.	29.8	29.4	24.9	24.4	19.3	30.7	30.4	26.0	25.6	20.0	31.5	31.5	27.0	26.7	20.7
	K.W.	2.39	2.39	2.39	2.42	2.47	2.40	2.40	2.40	2.43	2.47	2.43	2.42	2.42	2.45	2.49
105	T.C.	31.7	31.5	31.1	33.5	36.5	32.6	32.2	31.7	34.0	37.0	33.5	32.8	32.3	34.6	37.5
	S.C.	28.3	27.9	24.0	23.7	18.6	29.1	28.8	25.0	24.8	19.3	29.9	29.7	26.0	25.9	20.0
	K.W.	2.77	2.76	2.75	2.78	2.84	2.78	2.77	2.76	2.80	2.85	2.80	2.79	2.78	2.83	2.86
115	T.C.	30.2	30.2	29.3	31.7	34.5	31.0	30.9	29.9	32.1	34.8	31.9	31.5	30.5	32.6	35.1
	S.C.	26.9	26.4	23.0	23.0	18.0	27.6	27.2	24.1	24.0	18.7	28.3	28.0	25.1	25.1	19.3
	K.W.	3.15	3.12	3.11	3.14	3.21	3.15	3.13	3.12	3.16	3.21	3.16	3.16	3.14	3.19	3.23
125	T.C.	28.6	28.9	27.4	29.8	32.4	29.4	29.6	28.1	30.2	32.6	30.2	30.3	28.7	30.6	32.8
	S.C.	25.5	24.9	22.1	22.3	17.4	26.1	25.7	23.2	23.3	18.0	26.8	26.3	24.3	24.3	18.7
	K.W.	3.53	3.48	3.47	3.49	3.57	3.52	3.50	3.47	3.52	3.58	3.52	3.52	3.49	3.56	3.59

NOTE: ALL CAPACITIES INCLUDE INDOOR FAN HEAT. KW VALUES ARE FOR THE SYSTEM (OUTDOOR + INDOOR).

Multipliers for determining the performance with other indoor sections.

NOTE: For dry bulb temperatures different than those listed (between 73-87 °F), sensible capacity increases by 1060 BTUH per 1000 CFM per degree above the listed temperature and decreases by 1060 BTUH per 1000 CFM per degree below the listed temperature.

HIGH CFM

Air Handlers	Coils	T.C.	S.C.	KW
-	FC/MC62	0.97	0.95	1.11
AHE36C	-	0.98	0.96	1.03
AHE42D	-	0.98	0.97	1.00
AHV36C	-	0.97	0.96	1.05
AHV42D	-	0.98	0.97	1.02
AHV48D	-	0.98	0.95	1.00
MV12B	FC/MC35B	0.96	0.93	1.05
MV12B	FC/MC43B	0.98	0.97	1.03
MV12D	FC/MC48D	0.98	0.96	1.00
MV12D	FC/MC60D	0.97	0.94	1.01
MV12D	FC/MC62D	1.00	1.00	1.00
MV12D	FC64D	1.01	1.00	1.00
MV16C	FC/MC35C	0.96	0.94	1.01

Air Handlers	Coils	T.C.	S.C.	KW
MV16C	FC/MC43C	0.97	0.96	1.03
MV16C	FC/MC48C	0.98	0.95	1.01
MV20D	FC/MC48D	1.00	1.01	1.02
MV20D	FC/MC60D	1.00	1.00	1.02
MV20D	FC/MC62D	1.01	1.02	1.03
MV20D	FC64D	1.03	1.06	1.03
MX12BN21	FC/MC35B	0.94	0.91	1.04
MX12BN21	FC/MC43B	0.96	0.92	1.03
MX12DN21	FC/MC48D	0.98	0.95	1.00
MX12DN21	FC/MC60D	0.98	0.95	1.00
MX12DN21	FC64D	1.01	1.02	1.00

Continued on next page.

Furnaces	Coils	T.C.	S.C.	KW
T*(8,L)V*A12	FC/MC/PC37A	0.96	0.92	1.07
T*(8,L)V*B12	FC/MC/PC35B	0.95	0.92	1.06
T*(8,L)V*B12	FC/MC/PC43B	0.97	0.97	1.11
T*(8,L)V*B12	HD48	0.98	0.95	1.06
T*(8,L)V*C16	FC/MC/PC35C	0.96	0.93	1.05
T*(8,L)V*C16	FC/MC/PC43C	0.97	0.95	1.03
T*(8,L)V*C16	FC/MC/PC48C	0.98	0.96	1.02
T*(8,L)V*C16	FC/PC60C	0.97	0.94	1.01
T*(8,L)V*C16	HD48	0.99	0.96	1.03
T*(8,L)V*C16	UC48C	0.97	0.94	1.02
T*(8,L)V*C16	UC60C	0.97	0.95	1.03
T*(8,L)V*C20	FC/MC/PC35C	0.95	0.92	1.04
T*(8,L)V*C20	FC/MC/PC43C	0.97	0.95	1.03
T*(8,L)V*C20	FC/MC/PC48C	0.98	0.95	1.01
T*(8,L)V*C20	FC/PC60C	0.98	0.97	1.02
T*(8,L)V*C20	HD48	0.98	0.95	1.02
T*(8,L)V*C20	UC48C	0.94	0.91	1.02
T*(8,L)V*C20	UC60C	0.97	0.95	1.03
T*9V*B12	FC/MC/PC35B	0.95	0.92	1.08
T*9V*B12	FC/MC/PC43B	0.96	0.95	1.07
T*9V*B12	HD48	0.97	0.92	1.07
T*9V*C16	FC/MC/PC35C	0.96	0.92	1.05
T*9V*C16	FC/MC/PC43C	0.97	0.97	1.07
T*9V*C16	FC/MC/PC48C	0.97	0.95	1.05
T*9V*C16	FC/PC60C	0.98	0.97	1.05
T*9V*C16	HD48	0.98	0.95	1.05
T*9V*C16	UC48C	0.94	0.90	1.03
T*9V*C16	UC60C	0.98	0.96	1.05
T*9V*C20	FC/MC/PC35C	0.97	0.97	1.08
T*9V*C20	FC/MC/PC43C	0.97	0.95	1.05
T*9V*C20	FC/MC/PC48C	0.99	1.01	1.07
T*9V*C20	FC/PC60C	0.99	1.00	1.06
T*9V*C20	HD48	1.00	0.99	1.08
T*9V*C20	UC48C	0.96	0.97	1.07
T*9V*C20	UC60C	0.99	1.00	1.06
T*9V*D20	FC/MC/PC48D	0.99	0.98	1.04
T*9V*D20	FC/MC/PC60D	0.98	0.97	1.04
T*9V*D20	FC/MC62D	0.99	0.99	1.03
T*9V*D20	FC64D	1.03	1.03	1.05
T*9V*D20	HD48	0.99	0.96	1.03
T*9V*D20	UC48D	0.96	0.94	1.03
T*9V*D20	UC60D	0.98	0.97	1.03
TM8X060A12MP11	FC/MC/PC37A	0.95	0.91	1.06
TM8X080B12MP11	FC/MC/PC35B	0.95	0.92	1.06
TM8X080B12MP11	FC/MC/PC43B	0.95	0.91	1.06
TM8X080B12MP11	HD48	0.98	0.95	1.02
TM8X080C16MP11	FC/MC/PC35C	0.95	0.91	1.02
TM8X080C16MP11	FC/MC/PC43C	0.96	0.92	1.03
TM8X080C16MP11	FC/MC/PC48C	0.98	0.95	1.03
TM8X080C16MP11	FC/MC/PC48D	0.98	0.95	1.03
TM8X080C16MP11	FC/MC/PC60D	0.98	0.95	1.03
TM8X080C16MP11	FC/MC62D	0.99	0.97	1.02
TM8X080C16MP11	FC/PC60C	0.98	0.95	1.03
TM8X080C16MP11	FC64D	1.01	1.00	1.03
TM8X080C16MP11	HD48	0.98	0.94	1.00
TM8X080C16MP11	UC48C	0.94	0.91	1.02
TM8X080C16MP11	UC48D	0.94	0.91	1.02
TM8X080C16MP11	UC60C	0.97	0.95	1.03
TM8X080C16MP11	UC60D	0.97	0.95	1.03
TM8X080C16MP11	FC/MC/PC35C	0.95	0.91	1.02
TM8X080C16MP11	FC/MC/PC43C	0.96	0.92	1.03
TM8X080C16MP11	FC/MC/PC48C	0.98	0.95	1.03
TM8X080C16MP11	FC/MC/PC48D	0.98	0.95	1.03
TM8X080C16MP11	FC/MC/PC60D	0.98	0.95	1.03
TM8X080C16MP11	FC/MC62D	0.99	0.97	1.02
TM8X080C16MP11	FC/PC60C	0.98	0.95	1.03
TM8X080C16MP11	FC64D	1.01	1.00	1.03
TM8X080C16MP11	HD48	0.98	0.94	1.00
TM8X080C16MP11	UC48C	0.94	0.91	1.02

Furnaces	Coils	T.C.	S.C.	KW
TM8X080C16MP11	UC48D	0.94	0.91	1.02
TM8X080C16MP11	UC60C	0.97	0.95	1.03
TM8X080C16MP11	UC60D	0.97	0.95	1.03
TM8X100C16MP11	FC/MC/PC35C	0.95	0.91	1.02
TM8X100C16MP11	FC/MC/PC43C	0.96	0.92	1.03
TM8X100C16MP11	FC/MC/PC48C	0.98	0.95	1.03
TM8X100C16MP11	FC/MC/PC48D	0.98	0.95	1.03
TM8X100C16MP11	FC/MC/PC60D	0.98	0.95	1.03
TM8X100C16MP11	FC/MC62D	0.99	0.97	1.02
TM8X100C16MP11	FC/PC60C	0.98	0.95	1.03
TM8X100C16MP11	FC64D	1.01	1.00	1.03
TM8X100C16MP11	HD48	0.98	0.94	1.00
TM8X100C16MP11	UC48C	0.94	0.91	1.02
TM8X100C16MP11	UC48D	0.94	0.91	1.02
TM8X100C16MP11	UC60C	0.97	0.95	1.03
TM8X100C16MP11	UC60D	0.97	0.95	1.03
TM8X100C20MP11	HD48	1.00	0.98	1.02
TM8X120C20MP11	HD48	1.00	0.98	1.02
TMLX060A12MP11	FC/MC/PC37A	0.95	0.91	1.06
TMLX080B12MP11	FC/MC/PC35B	0.95	0.92	1.06
TMLX080B12MP11	FC/MC/PC43B	0.95	0.91	1.06
TMLX080B12MP11	HD48	0.98	0.95	1.02
TMLX080C16MP11	FC/MC/PC35C	0.95	0.91	1.02
TMLX080C16MP11	FC/MC/PC43C	0.96	0.92	1.03
TMLX080C16MP11	FC/MC/PC48C	0.98	0.95	1.03
TMLX080C16MP11	FC/MC/PC48D	0.98	0.95	1.03
TMLX080C16MP11	FC/MC/PC60D	0.98	0.95	1.03
TMLX080C16MP11	FC/MC62D	0.99	0.97	1.02
TMLX080C16MP11	FC/PC60C	0.98	0.95	1.03
TMLX080C16MP11	FC64D	1.01	1.00	1.03
TMLX080C16MP11	HD48	0.98	0.94	1.00
TMLX080C16MP11	UC48C	0.94	0.91	1.02
TMLX080C16MP11	UC48D	0.94	0.91	1.02
TMLX080C16MP11	UC60C	0.97	0.95	1.03
TMLX080C16MP11	UC60D	0.97	0.95	1.03
TMLX100C16MP11	FC/MC/PC35C	0.95	0.91	1.02
TMLX100C16MP11	FC/MC/PC43C	0.96	0.92	1.03
TMLX100C16MP11	FC/MC/PC48C	0.98	0.95	1.03
TMLX100C16MP11	FC/MC/PC48D	0.98	0.95	1.03
TMLX100C16MP11	FC/MC/PC60D	0.98	0.95	1.03
TMLX100C16MP11	FC/MC62D	0.99	0.97	1.02
TMLX100C16MP11	FC/PC60C	0.98	0.95	1.03
TMLX100C16MP11	FC64D	1.01	1.00	1.03
TMLX100C16MP11	HD48	0.98	0.94	1.00
TMLX100C16MP11	UC48C	0.94	0.91	1.02
TMLX100C16MP11	UC48D	0.94	0.91	1.02
TMLX100C16MP11	UC60C	0.97	0.95	1.03
TMLX100C16MP11	UC60D	0.97	0.95	1.03
TMLX100C16MP11	FC/MC/PC35C	0.94	0.90	1.07
TMLX100C16MP11	FC/MC/PC43B	0.95	0.91	1.06
TMLX100C16MP11	HD48	0.99	0.99	1.05
TMLX100C16MP11	FC/MC/PC35B	0.94	0.90	1.07
TMLX100C16MP11	FC/MC/PC43B	0.95	0.91	1.06

Continued on next page.

Furnaces	Coils	T.C.	S.C.	KW
TM9E080B12MP11	HD48	0.99	0.99	1.05
TM9E080C16MP11	FC/MC/PC48D	0.97	0.95	1.05
TM9E080C16MP11	FC/MC62D	0.98	0.96	1.04
TM9E080C16MP11	FC64D	1.01	0.99	1.05
TM9E080C16MP11	HD48	1.00	1.01	1.04
TM9E080C16MP11	UC48D	0.94	0.90	1.03
TM9E100C16MP11	FC/MC/PC48D	0.97	0.95	1.05
TM9E100C16MP11	FC/MC62D	0.98	0.96	1.04
TM9E100C16MP11	FC64D	1.01	0.99	1.05
TM9E100C16MP11	HD48	1.00	1.01	1.04
TM9E100C16MP11	UC48D	0.94	0.90	1.03
TM9E100C20MP11	HD48	1.00	0.98	1.02
TM9E120D20MP11	HD48	1.00	0.98	1.02
TM9X060B12MP11	FC/MC/PC35B	0.94	0.90	1.07
TM9X060B12MP11	FC/MC/PC43B	0.95	0.91	1.06
TM9X060B12MP11	HD48	0.99	0.99	1.05
TM9X080B12MP11	FC/MC/PC35B	0.94	0.90	1.07
TM9X080B12MP11	FC/MC/PC43B	0.95	0.91	1.06
TM9X080B12MP11	HD48	0.99	0.99	1.05
TM9X080C16MP11	FC/MC/PC48D	0.97	0.95	1.05
TM9X080C16MP11	FC/MC62D	0.98	0.96	1.04
TM9X080C16MP11	FC64D	1.01	0.99	1.05
TM9X080C16MP11	HD48	1.00	1.01	1.04
TM9X080C16MP11	UC48D	0.94	0.90	1.03
TM9X100C16MP11	FC/MC/PC48D	0.97	0.95	1.05
TM9X100C16MP11	FC/MC62D	0.98	0.96	1.04
TM9X100C16MP11	FC64D	1.01	0.99	1.05
TM9X100C16MP11	HD48	1.00	1.01	1.04
TM9X100C16MP11	UC48D	0.94	0.90	1.03
TM9X100C20MP11	HD48	1.00	0.98	1.02
TM9X120D20MP11	HD48	1.00	0.98	1.02
L*LC*A12	FC/MC/PC37A	0.96	0.92	1.07
L*LC*B12	FC/MC/PC35B	0.95	0.92	1.06
L*LC*B12	FC/MC/PC43B	0.97	0.97	1.11
L*LC*B12	HD48	0.98	0.95	1.06
L*LC*C16	FC/MC/PC35C	0.96	0.93	1.05
L*LC*C16	FC/MC/PC43C	0.97	0.95	1.03
L*LC*C16	FC/MC/PC48C	0.98	0.96	1.02

Furnaces	Coils	T.C.	S.C.	KW
L*LC*C16	FC/PC60C	0.97	0.94	1.01
L*LC*C16	HD48	0.99	0.96	1.03
L*LC*C16	UC48C	0.97	0.94	1.02
L*LC*C16	UC60C	0.97	0.95	1.03
L*LC*C20	FC/MC/PC35C	0.95	0.92	1.04
L*LC*C20	FC/MC/PC43C	0.97	0.95	1.03
L*LC*C20	FC/MC/PC48C	0.98	0.95	1.01
L*LC*C20	FC/PC60C	0.98	0.97	1.02
L*LC*C20	HD48	0.98	0.95	1.02
L*LC*C20	UC48C	0.94	0.91	1.02
L*LC*C20	UC60C	0.97	0.95	1.03
L*9C*B12	FC/MC/PC35B	0.95	0.92	1.08
L*9C*B12	FC/MC/PC43B	0.96	0.95	1.07
L*9C*B12	HD48	0.97	0.92	1.07
L*9C*C16	FC/MC/PC35C	0.96	0.92	1.05
L*9C*C16	FC/MC/PC43C	0.97	0.97	1.07
L*9C*C16	FC/MC/PC48C	0.97	0.95	1.05
L*9C*C16	FC/PC60C	0.98	0.97	1.05
L*9C*C16	HD48	0.98	0.95	1.05
L*9C*C16	UC48C	0.94	0.90	1.03
L*9C*C16	UC60C	0.98	0.96	1.05
L*9C*C20	FC/MC/PC35C	0.97	0.97	1.08
L*9C*C20	FC/MC/PC43C	0.97	0.95	1.05
L*9C*C20	FC/MC/PC48C	0.99	1.01	1.07
L*9C*C20	FC/PC60C	0.99	1.00	1.06
L*9C*C20	HD48	1.00	0.99	1.08
L*9C*C20	UC48C	0.96	0.97	1.07
L*9C*C20	UC60C	0.99	1.00	1.06
L*9C*D20	FC/MC/PC48D	0.99	0.98	1.04
L*9C*D20	FC/MC/PC60D	0.98	0.97	1.04
L*9C*D20	FC/MC62D	0.99	0.99	1.03
L*9C*D20	FC64D	1.03	1.03	1.05
L*9C*D20	HD48	0.99	0.96	1.03
L*9C*D20	UC48D	0.96	0.94	1.03
L*9C*D20	UC60D	0.98	0.97	1.03

COOLING PERFORMANCE DATA - LOW CFM 1-STAGE OPERATION																
OUTDOOR UNIT MODEL NO.		AL8B048F4C														
INDOOR COIL MODEL NO.		FC62D + MV20D														
AIR TEMP. ENTERING OUTDOOR UNIT (°F)	ID CFM	1075					1125					1175				
	ID DB (°F)	80	80	75	80	80	80	80	75	80	80	80	80	75	80	80
	ID WB (°F)	57	62	62	67	72	57	62	62	67	72	57	62	62	67	72
65	T.C.	35.5	36.2	36.6	40.5	43.4	36.1	37.0	37.1	40.6	43.9	36.8	37.8	37.5	40.7	44.3
	S.C.	33.2	30.0	25.8	25.6	20.7	33.8	31.0	26.4	26.3	21.1	34.3	32.0	27.0	27.0	21.5
	K.W.	1.47	1.46	1.47	1.42	1.39	1.46	1.46	1.46	1.42	1.38	1.46	1.46	1.46	1.42	1.38
75	T.C.	33.8	34.6	35.0	38.6	41.5	34.4	35.3	35.3	38.8	41.9	34.9	35.9	35.7	38.9	42.3
	S.C.	31.8	29.3	25.1	25.0	20.0	32.3	30.2	25.6	25.6	20.4	32.8	31.1	26.2	26.3	20.7
	K.W.	1.82	1.81	1.82	1.78	1.75	1.82	1.81	1.82	1.77	1.74	1.81	1.81	1.81	1.77	1.74
85	T.C.	32.1	33.1	33.4	36.7	39.6	32.6	33.6	33.6	36.9	39.9	33.1	34.1	33.8	37.2	40.3
	S.C.	30.3	28.7	24.4	24.3	19.3	30.8	29.4	24.9	24.9	19.6	31.2	30.2	25.4	25.5	20.0
	K.W.	2.18	2.17	2.18	2.14	2.11	2.17	2.16	2.17	2.13	2.10	2.16	2.16	2.16	2.13	2.10
95	T.C.	30.3	31.6	31.7	34.8	37.7	30.8	31.9	31.8	35.1	38.0	31.2	32.3	31.9	35.4	38.3
	S.C.	28.9	28.0	23.7	23.7	18.5	29.3	28.6	24.1	24.2	18.9	29.7	29.3	24.5	24.7	19.2
	K.W.	2.53	2.52	2.53	2.50	2.47	2.53	2.52	2.53	2.49	2.47	2.52	2.52	2.52	2.48	2.46
105	T.C.	28.9	29.6	29.5	32.5	35.2	29.3	29.9	29.6	32.8	35.5	29.7	30.2	29.7	33.0	35.7
	S.C.	27.2	26.7	22.6	22.7	17.7	27.7	27.2	23.1	23.2	18.0	28.1	27.7	23.5	23.7	18.3
	K.W.	3.02	3.00	3.00	2.97	2.95	3.01	3.00	3.00	2.96	2.94	3.00	2.99	2.99	2.96	2.94
115	T.C.	27.4	27.7	27.2	30.3	32.8	27.9	27.9	27.4	30.5	33.1	28.3	28.1	27.6	30.8	33.3
	S.C.	25.7	25.4	21.5	21.8	16.8	26.1	25.9	22.0	22.2	17.1	26.5	26.3	22.5	22.7	17.4
	K.W.	3.48	3.46	3.46	3.43	3.41	3.48	3.46	3.46	3.42	3.40	3.47	3.45	3.45	3.42	3.40
125	T.C.	26.0	25.9	25.0	28.0	30.4	26.4	25.9	25.3	28.3	30.6	26.9	26.0	25.5	28.5	30.8
	S.C.	24.1	24.2	20.5	20.8	15.9	24.5	24.5	21.0	21.2	16.2	24.9	24.8	21.5	21.6	16.6
	K.W.	3.95	3.93	3.92	3.89	3.87	3.94	3.92	3.91	3.88	3.87	3.94	3.91	3.91	3.88	3.86

NOTE: ALL CAPACITIES INCLUDE INDOOR FAN HEAT. KW VALUES ARE FOR THE SYSTEM (OUTDOOR + INDOOR).

Multipliers for determining the performance with other indoor sections.

NOTE: For dry bulb temperatures different than those listed (between 73-87 °F), sensible capacity increases by 1060 BTUH per 1000 CFM per degree above the listed temperature and decreases by 1060 BTUH per 1000 CFM per degree below the listed temperature.

LOW CFM

Air Handlers	Coils	T.C.	S.C.	KW
-	FC/MC62	0.99	0.99	1.19
AHE48D	-	0.96	0.92	1.02
AHE60D	-	1.00	1.01	1.03
AHV48D	-	0.98	0.95	1.00
AHV60D	-	0.98	0.95	1.01
MV16C	FC/MC48C	0.99	0.95	1.04
MV16C	FC60C	0.98	0.95	1.03
MV20D	FC/MC48D	0.99	0.95	1.03
MV20D	FC/MC60D	0.98	0.95	1.05
MV20D	FC/MC62D	1.00	1.00	1.00
MV20D	FC64D	1.03	1.02	0.99
MX16CN21	FC/MC48C	0.99	0.96	1.01
MX16CN21	FC60C	0.99	0.95	1.01

Continued on next page.

Furnaces	Coils	T.C.	S.C.	KW
T*(8,L)V*C16	FC/MC/PC48C	1.00	0.98	1.07
T*(8,L)V*C16	FC/MC/PC48D	1.00	0.98	1.07
T*(8,L)V*C16	FC/MC/PC60D	0.98	0.95	1.05
T*(8,L)V*C16	FC/MC62D	0.98	0.95	1.04
T*(8,L)V*C16	FC/PC60C	0.98	0.95	1.05
T*(8,L)V*C16	FC64D	1.01	1.02	1.02
T*(8,L)V*C16	HD60	0.99	0.97	1.04
T*(8,L)V*C16	UC48C	0.95	0.92	1.06
T*(8,L)V*C16	UC60C	0.98	0.94	1.05
T*(8,L)V*C20	FC/MC/PC48C	0.98	0.95	1.04
T*(8,L)V*C20	FC/MC/PC48D	0.98	0.95	1.04
T*(8,L)V*C20	FC/MC/PC60D	0.98	0.95	1.05
T*(8,L)V*C20	FC/MC62D	0.99	0.97	1.04
T*(8,L)V*C20	FC/PC60C	0.98	0.95	1.05
T*(8,L)V*C20	FC64D	1.01	1.02	1.02
T*(8,L)V*C20	HD60	0.99	0.96	1.03
T*(8,L)V*C20	UC48C	0.96	0.94	1.08
T*(8,L)V*C20	UC60C	0.96	0.94	1.03
T*9V*C16	FC/MC/PC48C	0.98	0.95	1.05
T*9V*C16	FC/MC/PC48D	0.98	0.95	1.05
T*9V*C16	FC/MC/PC60D	0.98	0.95	1.07
T*9V*C16	FC/MC62D	0.98	0.95	1.05
T*9V*C16	FC/PC60C	0.98	0.95	1.07
T*9V*C16	FC64D	1.01	1.02	1.03
T*9V*C16	HD60	0.99	0.97	1.06
T*9V*C16	UC48C	0.94	0.92	1.08
T*9V*C16	UC60C	0.96	0.93	1.07
T*9V*C20	FC/MC/PC48C	0.98	0.95	1.05
T*9V*C20	FC/MC/PC48D	0.98	0.95	1.05
T*9V*C20	FC/MC/PC60D	0.98	0.95	1.05
T*9V*C20	FC/MC62D	0.98	0.95	1.04
T*9V*C20	FC/PC60C	0.98	0.95	1.05
T*9V*C20	FC64D	1.01	1.02	1.03
T*9V*C20	HD60	0.99	0.97	1.04
T*9V*C20	UC48C	0.95	0.92	1.07
T*9V*C20	UC60C	0.96	0.95	1.05
T*9V*D20	FC/MC/PC48D	0.98	0.95	1.05
T*9V*D20	FC/MC/PC60D	0.98	0.95	1.05
T*9V*D20	FC/MC62D	0.99	0.97	1.06
T*9V*D20	FC64D	1.01	1.02	1.05
T*9V*D20	HD60	1.00	1.00	1.04
T*9V*D20	UC48D	0.95	0.92	1.07
T*9V*D20	UC60D	0.98	0.95	1.07
TM8X080C16MP11	FC/MC/PC48C	0.99	0.95	1.03
TM8X080C16MP11	FC/MC/PC48D	0.99	0.95	1.03
TM8X080C16MP11	FC/MC/PC60D	0.98	0.95	1.02
TM8X080C16MP11	FC/MC62D	0.98	0.96	1.02
TM8X080C16MP11	FC/PC60C	0.98	0.95	1.03
TM8X080C16MP11	FC64D	1.03	1.02	1.01
TM8X080C16MP11	HD60	1.00	1.00	1.03
TM8X080C16MP11	UC48C	0.95	0.92	1.03
TM8X080C16MP11	UC48D	0.95	0.92	1.03
TM8X080C16MP11	UC60C	0.96	0.94	1.03
TM8X080C16MP11	UC60D	0.96	0.94	1.03
TM8X080C16MP11	UC48C	0.95	0.92	1.03
TM8X080C16MP11	UC48D	0.95	0.92	1.03
TM8X080C16MP11	UC60C	0.96	0.94	1.03
TM8X080C16MP11	UC60D	0.96	0.94	1.03
TM8X100C16MP11	FC/MC/PC48C	0.99	0.95	1.03
TM8X100C16MP11	FC/MC/PC48D	0.99	0.95	1.03
TM8X100C16MP11	FC/MC/PC60D	0.98	0.95	1.02
TM8X100C16MP11	FC/MC62D	0.98	0.96	1.02
TM8X100C16MP11	FC/PC60C	0.98	0.95	1.03
TM8X100C16MP11	FC64D	1.03	1.02	1.01
TM8X100C16MP11	HD60	1.00	1.00	1.03
TM8X100C16MP11	UC48C	0.95	0.92	1.03
TM8X100C16MP11	UC48D	0.95	0.92	1.03
TM8X100C16MP11	UC60C	0.96	0.94	1.03
TM8X100C16MP11	UC60D	0.96	0.94	1.03
TM8X100C20MP11	FC/MC/PC48C	0.99	0.98	1.03
TM8X100C20MP11	FC/MC/PC48D	1.00	0.98	1.03
TM8X100C20MP11	FC/MC/PC60D	0.99	0.98	1.03
TM8X100C20MP11	FC/MC62D	1.00	0.99	1.04
TM8X100C20MP11	FC/PC60C	0.98	0.95	1.04
TM8X100C20MP11	HD60	0.94	0.89	1.00
TM8X100C20MP11	UC48C	0.96	0.94	1.05
TM8X100C20MP11	UC48D	0.96	0.94	1.04
TM8X100C20MP11	UC60C	0.98	0.96	1.03
TM8X100C20MP11	UC60D	0.99	0.97	1.04
TM8X120C20MP11	FC/MC/PC48C	0.99	0.98	1.03
TM8X120C20MP11	FC/MC/PC48D	1.00	0.98	1.03
TM8X120C20MP11	FC/MC/PC60D	0.99	0.98	1.03
TM8X120C20MP11	FC/MC62D	1.00	0.99	1.04
TM8X120C20MP11	FC/PC60C	0.98	0.95	1.04
TM8X120C20MP11	HD60	0.94	0.89	1.00
TM8X120C20MP11	UC48C	0.96	0.94	1.05
TM8X120C20MP11	UC48D	0.96	0.94	1.04
TM8X120C20MP11	UC60C	0.98	0.96	1.03
TM8X120C20MP11	UC60D	0.99	0.97	1.04
TMLX080C16MP11	FC/MC/PC48C	0.99	0.95	1.03
TMLX080C16MP11	FC/MC/PC48D	0.99	0.95	1.03
TMLX080C16MP11	FC/MC/PC60D	0.98	0.95	1.02
TMLX080C16MP11	FC/MC62D	0.98	0.96	1.02
TMLX080C16MP11	FC/PC60C	0.98	0.95	1.03
TMLX080C16MP11	FC64D	1.03	1.02	1.01
TMLX080C16MP11	HD60	1.00	1.00	1.03
TMLX080C16MP11	UC48C	0.95	0.92	1.03
TMLX080C16MP11	UC48D	0.95	0.92	1.03
TMLX080C16MP11	UC60C	0.96	0.94	1.03
TMLX080C16MP11	UC60D	0.96	0.94	1.03
TMLX100C16MP11	FC/MC/PC48C	0.99	0.95	1.03
TMLX100C16MP11	FC/MC/PC48D	0.99	0.95	1.03
TMLX100C16MP11	FC/MC/PC60D	0.98	0.95	1.02
TMLX100C16MP11	FC/MC62D	0.98	0.96	1.02
TMLX100C16MP11	FC/PC60C	0.98	0.95	1.03
TMLX100C16MP11	FC64D	1.03	1.02	1.01
TMLX100C16MP11	HD60	1.00	1.00	1.03
TMLX100C16MP11	UC48C	0.95	0.92	1.03
TMLX100C16MP11	UC48D	0.95	0.92	1.03
TMLX100C16MP11	UC60C	0.96	0.94	1.03
TMLX100C16MP11	UC60D	0.96	0.94	1.03
TMLX100C20MP11	FC/MC/PC48C	0.99	0.98	1.03
TMLX100C20MP11	FC/MC/PC48D	1.00	0.98	1.03
TMLX100C20MP11	FC/MC/PC60D	0.99	0.98	1.03
TMLX100C20MP11	FC/MC62D	1.00	0.99	1.04

Furnaces	Coils	T.C.	S.C.	KW
TM8X100C16MP11	FC/MC/PC60D	0.98	0.95	1.02
TM8X100C16MP11	FC/MC62D	0.98	0.96	1.02
TM8X100C16MP11	FC/PC60C	0.98	0.95	1.03
TM8X100C16MP11	FC64D	1.03	1.02	1.01
TM8X100C16MP11	HD60	1.00	1.00	1.03
TM8X100C16MP11	UC48C	0.95	0.92	1.03
TM8X100C16MP11	UC48D	0.95	0.92	1.03
TM8X100C16MP11	UC60C	0.96	0.94	1.03
TM8X100C16MP11	UC60D	0.96	0.94	1.03
TM8X100C20MP11	FC/MC/PC48C	0.99	0.98	1.03
TM8X100C20MP11	FC/MC/PC48D	1.00	0.98	1.03
TM8X100C20MP11	FC/MC/PC60D	0.99	0.98	1.03
TM8X100C20MP11	FC/MC62D	1.00	0.99	1.04
TM8X100C20MP11	FC/PC60C	0.98	0.95	1.04
TM8X100C20MP11	HD60	0.94	0.89	1.00
TM8X100C20MP11	UC48C	0.96	0.94	1.05
TM8X100C20MP11	UC48D	0.96	0.94	1.04
TM8X100C20MP11	UC60C	0.98	0.96	1.03
TM8X100C20MP11	UC60D	0.99	0.97	1.04
TM8X120C20MP11	FC/MC/PC48C	0.99	0.98	1.03
TM8X120C20MP11	FC/MC/PC48D	1.00	0.98	1.03
TM8X120C20MP11	FC/MC/PC60D	0.99	0.98	1.03
TM8X120C20MP11	FC/MC62D	1.00	0.99	1.04
TM8X120C20MP11	FC/PC60C	0.98	0.95	1.04
TM8X120C20MP11	HD60	0.94	0.89	1.00
TM8X120C20MP11	UC48C	0.96	0.94	1.05
TM8X120C20MP11	UC48D	0.96	0.94	1.04
TM8X120C20MP11	UC60C	0.98	0.96	1.03
TM8X120C20MP11	UC60D	0.99	0.97	1.04
TMLX080C16MP11	FC/MC/PC48C	0.99	0.95	1.03
TMLX080C16MP11	FC/MC/PC48D	0.99	0.95	1.03
TMLX080C16MP11	FC/MC/PC60D	0.98	0.95	1.02
TMLX080C16MP11	FC/MC62D	0.98	0.96	1.02
TMLX080C16MP11	FC/PC60C	0.98	0.95	1.03
TMLX080C16MP11	FC64D	1.03	1.02	1.01
TMLX080C16MP11	HD60	1.00	1.00	1.03
TMLX080C16MP11	UC48C	0.95	0.92	1.03
TMLX080C16MP11	UC48D	0.95	0.92	1.03
TMLX080C16MP11	UC60C	0.96	0.94	1.03
TMLX080C16MP11	UC60D	0.96	0.94	1.03
TMLX100C16MP11	FC/MC/PC48C	0.99	0.95	1.03
TMLX100C16MP11	FC/MC/PC48D	0.99	0.95	1.03
TMLX100C16MP11	FC/MC/PC60D	0.98	0.95	1.02
TMLX100C16MP11	FC/MC62D	0.98	0.96	1.02
TMLX100C16MP11	FC/PC60C	0.98	0.95	1.03
TMLX100C16MP11	FC64D	1.03	1.02	1.01
TMLX100C16MP11	HD60	1.00	1.00	1.03
TMLX100C16MP11	UC48C	0.95	0.92	1.03
TMLX100C16MP11	UC48D	0.95	0.92	1.03
TMLX100C16MP11	UC60C	0.96	0.94	1.03
TMLX100C16MP11	UC60D	0.96	0.94	1.03
TMLX100C20MP11	FC/MC/PC48C	0.99	0.98	1.03
TMLX100C20MP11	FC/MC/PC48D	1.00	0.98	1.03
TMLX100C20MP11	FC/MC/PC60D	0.99	0.98	1.03
TMLX100C20MP11	FC/MC62D	1.00	0.99	1.04

Continued on next page.

Furnaces	Coils	T.C.	S.C.	KW
TMLX100C20MP11	FC/PC60C	0.98	0.95	1.04
TMLX100C20MP11	HD60	0.94	0.89	1.00
TMLX100C20MP11	UC48C	0.96	0.94	1.05
TMLX100C20MP11	UC48D	0.96	0.94	1.04
TMLX100C20MP11	UC60C	0.98	0.96	1.03
TMLX100C20MP11	UC60D	0.99	0.97	1.04
TMLX120C20MP11	FC/MC/PC48C	0.99	0.98	1.03
TMLX120C20MP11	FC/MC/PC48D	1.00	0.98	1.03
TMLX120C20MP11	FC/MC/PC60D	0.99	0.98	1.03
TMLX120C20MP11	FC/MC62D	1.00	0.99	1.04
TMLX120C20MP11	FC/PC60C	0.98	0.95	1.04
TMLX120C20MP11	HD60	0.94	0.89	1.00
TMLX120C20MP11	UC48C	0.96	0.94	1.05
TMLX120C20MP11	UC48D	0.96	0.94	1.04
TMLX120C20MP11	UC60C	0.98	0.96	1.03
TMLX120C20MP11	UC60D	0.99	0.97	1.04
TM9E080C16MP11	HD60	1.00	1.00	1.03
TM9E100C16MP11	HD60	1.00	1.00	1.03
TM9E100C20MP11	FC/MC/PC48C	0.96	0.92	1.03
TM9E100C20MP11	FC/MC/PC48D	0.96	0.92	1.02
TM9E100C20MP11	FC/MC/PC60D	0.96	0.92	1.02
TM9E100C20MP11	FC/MC62D	0.98	0.94	1.02
TM9E100C20MP11	FC64D	1.00	0.98	1.00
TM9E100C20MP11	HD60	1.03	1.02	1.06
TM9E100C20MP11	UC48C	0.93	0.89	1.04
TM9E100C20MP11	UC48D	0.94	0.89	1.04
TM9E100C20MP11	UC60D	0.96	0.92	1.03
TM9E120D20MP11	FC/MC/PC48D	0.96	0.93	1.02
TM9E120D20MP11	FC/MC/PC60D	0.98	0.93	1.02
TM9E120D20MP11	FC/MC62D	0.98	0.94	1.02
TM9E120D20MP11	FC64D	1.00	0.97	1.00
TM9E120D20MP11	HD60	1.03	1.05	1.06
TM9E120D20MP11	UC48D	0.93	0.89	1.03
TM9E120D20MP11	UC60D	0.98	0.94	1.02
TM9X080C16MP11	HD60	1.00	1.00	1.03
TM9X100C16MP11	HD60	1.00	1.00	1.03
TM9X100C20MP11	FC/MC/PC48C	0.96	0.92	1.03
TM9X100C20MP11	FC/MC/PC48D	0.96	0.92	1.02
TM9X100C20MP11	FC/MC/PC60D	0.96	0.92	1.02
TM9X100C20MP11	FC/MC62D	0.98	0.94	1.02
TM9X100C20MP11	FC64D	1.00	0.98	1.00
TM9X100C20MP11	HD60	1.03	1.02	1.06
TM9X100C20MP11	UC48C	0.93	0.89	1.04
TM9X100C20MP11	UC48D	0.94	0.89	1.04
TM9X100C20MP11	UC60D	0.96	0.92	1.03
TM9X120D20MP11	FC/MC/PC48D	0.96	0.93	1.02
TM9X120D20MP11	FC/MC/PC60D	0.98	0.93	1.02
TM9X120D20MP11	FC/MC62D	0.98	0.94	1.02
TM9X120D20MP11	FC64D	1.00	0.97	1.00

Furnaces	Coils	T.C.	S.C.	KW
TM9X120D20MP11	HD60	1.03	1.05	1.06
TM9X120D20MP11	UC48D	0.93	0.89	1.03
TM9X120D20MP11	UC60D	0.98	0.94	1.02
L*LC*C16	FC/MC/PC48C	1.00	0.98	1.07
L*LC*C16	FC/MC/PC48D	1.00	0.98	1.07
L*LC*C16	FC/MC/PC60D	0.98	0.95	1.05
L*LC*C16	FC/MC62D	0.98	0.95	1.04
L*LC*C16	FC/PC60C	0.98	0.95	1.05
L*LC*C16	FC64D	1.01	1.02	1.02
L*LC*C16	HD60	0.99	0.97	1.04
L*LC*C16	UC48C	0.95	0.92	1.06
L*LC*C16	UC60C	0.98	0.94	1.05
L*LC*C20	FC/MC/PC48C	0.98	0.95	1.04
L*LC*C20	FC/MC/PC48D	0.98	0.95	1.04
L*LC*C20	FC/MC/PC60D	0.98	0.95	1.05
L*LC*C20	FC/MC62D	0.99	0.97	1.04
L*LC*C20	FC/PC60C	0.98	0.95	1.05
L*LC*C20	FC64D	1.01	1.02	1.02
L*LC*C20	HD60	0.99	0.96	1.03
L*LC*C20	UC48C	0.96	0.94	1.08
L*LC*C20	UC60C	0.96	0.94	1.03
L*9C*C16	FC/MC/PC48C	0.98	0.95	1.05
L*9C*C16	FC/MC/PC48D	0.98	0.95	1.05
L*9C*C16	FC/MC/PC60D	0.98	0.95	1.07
L*9C*C16	FC/MC62D	0.98	0.95	1.05
L*9C*C16	FC/PC60C	0.98	0.95	1.07
L*9C*C16	FC64D	1.01	1.02	1.03
L*9C*C16	HD60	0.99	0.97	1.06
L*9C*C16	UC48C	0.94	0.92	1.08
L*9C*C16	UC60C	0.96	0.93	1.07
L*9C*C20	FC/MC/PC48C	0.98	0.95	1.05
L*9C*C20	FC/MC/PC48D	0.98	0.95	1.05
L*9C*C20	FC/MC/PC60D	0.98	0.95	1.05
L*9C*C20	FC/MC62D	0.98	0.95	1.04
L*9C*C20	FC/PC60C	0.98	0.95	1.05
L*9C*C20	FC64D	1.01	1.02	1.03
L*9C*C20	HD60	0.99	0.97	1.04
L*9C*C20	UC48C	0.95	0.92	1.07
L*9C*C20	UC60C	0.96	0.95	1.05
L*9C*D20	FC/MC/PC48D	0.98	0.95	1.05
L*9C*D20	FC/MC/PC60D	0.98	0.95	1.05
L*9C*D20	FC/MC62D	0.99	0.97	1.06
L*9C*D20	FC64D	1.01	1.02	1.05
L*9C*D20	HD60	1.00	1.00	1.04
L*9C*D20	UC48D	0.95	0.92	1.07
L*9C*D20	UC60D	0.98	0.95	1.07

COOLING PERFORMANCE DATA - HIGH CFM 2-STAGE OPERATION																
OUTDOOR UNIT MODEL NO.		AL8B048F4C														
INDOOR COIL MODEL NO.		FC62D + MV20D														
AIR TEMP. ENTERING OUTDOOR UNIT (°F)	ID CFM	1600					1700					1800				
	ID DB (°F)	80	80	75	80	80	80	80	75	80	80	80	80	75	80	80
	ID WB (°F)	57	62	62	67	72	57	62	62	67	72	57	62	62	67	72
65	T.C.	47.1	48.4	49.2	52.7	57.2	47.9	49.2	49.5	53.2	57.6	48.7	50.0	49.8	53.7	58.0
	S.C.	45.8	41.9	35.3	35.1	28.0	46.7	42.9	36.2	35.9	28.2	47.6	43.9	37.1	36.7	28.4
	K.W.	2.42	2.43	2.44	2.48	2.53	2.46	2.47	2.48	2.52	2.58	2.51	2.51	2.52	2.58	2.63
75	T.C.	45.5	46.9	47.3	50.7	54.9	46.2	47.6	47.5	51.1	55.3	46.9	48.3	47.8	51.6	55.7
	S.C.	44.1	41.2	34.4	34.3	27.1	45.0	42.1	35.3	35.1	27.4	45.8	43.1	36.2	35.9	27.7
	K.W.	2.82	2.82	2.83	2.87	2.93	2.86	2.86	2.87	2.91	2.97	2.92	2.90	2.92	2.96	3.02
85	T.C.	43.8	45.4	45.4	48.6	52.6	44.5	46.0	45.6	49.1	53.0	45.2	46.6	45.8	49.5	53.4
	S.C.	42.5	40.4	33.6	33.4	26.2	43.2	41.3	34.5	34.2	26.6	44.0	42.3	35.4	35.0	27.0
	K.W.	3.22	3.21	3.22	3.26	3.32	3.27	3.25	3.26	3.30	3.36	3.32	3.29	3.31	3.35	3.42
95	T.C.	42.2	43.8	43.5	46.6	50.3	42.8	44.4	43.6	47.0	50.7	43.4	44.8	43.7	47.4	51.0
	S.C.	40.8	39.7	32.7	32.6	25.3	41.5	40.6	33.6	33.4	25.8	42.2	41.4	34.5	34.2	26.3
	K.W.	3.62	3.60	3.61	3.65	3.72	3.67	3.64	3.65	3.69	3.76	3.72	3.69	3.70	3.73	3.81
105	T.C.	40.5	41.2	41.0	43.9	47.4	41.1	41.5	41.1	44.2	47.7	41.7	41.9	41.1	44.5	48.1
	S.C.	38.8	38.0	31.8	31.4	24.2	39.4	38.7	32.5	32.1	24.6	40.0	39.5	33.1	32.9	25.1
	K.W.	4.21	4.17	4.18	4.22	4.29	4.25	4.21	4.22	4.25	4.32	4.30	4.26	4.27	4.30	4.37
115	T.C.	38.9	38.5	38.7	41.3	44.6	39.5	38.8	38.7	41.5	44.9	40.1	39.0	38.6	41.8	45.2
	S.C.	36.9	36.4	30.9	30.2	23.1	37.4	37.0	31.4	31.0	23.5	37.9	37.5	31.8	31.7	23.9
	K.W.	4.78	4.73	4.74	4.77	4.84	4.81	4.77	4.78	4.80	4.87	4.86	4.82	4.83	4.85	4.91
125	T.C.	37.3	35.9	36.3	38.7	41.8	37.9	36.1	36.2	38.8	42.0	38.5	36.2	36.1	39.0	42.3
	S.C.	35.0	34.8	30.0	29.0	22.0	35.4	35.2	30.2	29.8	22.4	35.9	35.6	30.4	30.5	22.7
	K.W.	5.34	5.28	5.30	5.32	5.39	5.38	5.33	5.34	5.35	5.42	5.42	5.38	5.39	5.39	5.45

NOTE: ALL CAPACITIES INCLUDE INDOOR FAN HEAT. KW VALUES ARE FOR THE SYSTEM (OUTDOOR + INDOOR).

Multipliers for determining the performance with other indoor sections.

NOTE: For dry bulb temperatures different than those listed (between 73-87 °F), sensible capacity increases by 1060 BTUH per 1000 CFM per degree above the listed temperature and decreases by 1060 BTUH per 1000 CFM per degree below the listed temperature.

HIGH CFM

Air Handlers	Coils	T.C.	S.C.	KW
-	FC/MC62	0.97	0.93	1.05
AHE48D	-	0.97	0.93	0.99
AHE60D	-	0.98	0.95	0.98
AHV48D	-	0.97	0.92	1.01
AHV60D	-	0.98	0.94	1.02
MV16C	FC/MC48C	0.97	0.95	1.01
MV16C	FC60C	0.97	0.93	1.01
MV20D	FC/MC48D	0.98	0.95	1.00
MV20D	FC/MC60D	0.97	0.93	1.01
MV20D	FC/MC62D	1.00	1.00	1.00
MV20D	FC64D	1.01	1.00	1.01
MX16CN21	FC/MC48C	0.97	0.94	1.01
MX16CN21	FC60C	0.97	0.93	1.01

Continued on next page.

Furnaces	Coils	T.C.	S.C.	KW
TMLX100C20MP11	FC/PC60C	0.97	0.93	1.03
TMLX100C20MP11	HD60	0.99	0.97	1.01
TMLX100C20MP11	UC48C	0.94	0.88	1.01
TMLX100C20MP11	UC48D	0.94	0.89	1.01
TMLX100C20MP11	UC60C	0.96	0.90	1.02
TMLX100C20MP11	UC60D	0.96	0.92	1.02
TMLX120C20MP11	FC/MC/PC48C	0.96	0.92	1.02
TMLX120C20MP11	FC/MC/PC48D	0.97	0.92	1.03
TMLX120C20MP11	FC/MC/PC60D	0.96	0.92	1.02
TMLX120C20MP11	FC/MC62D	0.98	0.93	1.02
TMLX120C20MP11	FC/PC60C	0.97	0.93	1.03
TMLX120C20MP11	HD60	0.99	0.97	1.01
TMLX120C20MP11	UC48C	0.94	0.88	1.01
TMLX120C20MP11	UC48D	0.94	0.89	1.01
TMLX120C20MP11	UC60C	0.96	0.90	1.02
TMLX120C20MP11	UC60D	0.96	0.92	1.02
TM9E080C16MP11	HD60	0.99	0.95	1.03
TM9E100C16MP11	HD60	0.99	0.95	1.03
TM9E100C20MP11	FC/MC/PC48C	0.95	0.90	1.05
TM9E100C20MP11	FC/MC/PC48D	0.96	0.90	1.04
TM9E100C20MP11	FC/MC/PC60D	0.95	0.89	1.03
TM9E100C20MP11	FC/MC62D	0.97	0.93	1.03
TM9E100C20MP11	FC64D	1.00	0.96	1.04
TM9E100C20MP11	HD60	0.99	0.95	1.01
TM9E100C20MP11	UC48C	0.93	0.86	1.05
TM9E100C20MP11	UC48D	0.93	0.87	1.02
TM9E100C20MP11	UC60D	0.95	0.89	1.03
TM9E120D20MP11	FC/MC/PC48D	0.96	0.91	1.02
TM9E120D20MP11	FC/MC/PC60D	0.96	0.90	1.02
TM9E120D20MP11	FC/MC62D	0.97	0.93	1.03
TM9E120D20MP11	FC64D	0.99	0.95	1.03
TM9E120D20MP11	HD60	0.99	0.96	1.01
TM9E120D20MP11	UC48D	0.93	0.87	1.02
TM9E120D20MP11	UC60D	0.95	0.90	1.03
TM9X080C16MP11	HD60	0.99	0.95	1.03
TM9X100C16MP11	HD60	0.99	0.95	1.03
TM9X100C20MP11	FC/MC/PC48C	0.95	0.90	1.05
TM9X100C20MP11	FC/MC/PC48D	0.96	0.90	1.04
TM9X100C20MP11	FC/MC/PC60D	0.95	0.89	1.03
TM9X100C20MP11	FC/MC62D	0.97	0.93	1.03
TM9X100C20MP11	FC64D	1.00	0.96	1.04
TM9X100C20MP11	HD60	0.99	0.95	1.01
TM9X100C20MP11	UC48C	0.93	0.86	1.05
TM9X100C20MP11	UC48D	0.93	0.87	1.02
TM9X100C20MP11	UC60D	0.95	0.89	1.03
TM9X120D20MP11	FC/MC/PC48D	0.96	0.91	1.02
TM9X120D20MP11	FC/MC/PC60D	0.96	0.90	1.02
TM9X120D20MP11	FC/MC62D	0.97	0.93	1.03
TM9X120D20MP11	FC64D	0.99	0.95	1.03

Furnaces	Coils	T.C.	S.C.	KW
TM9X120D20MP11	HD60	0.99	0.96	1.01
TM9X120D20MP11	UC48D	0.93	0.87	1.02
TM9X120D20MP11	UC60D	0.95	0.90	1.03
L*LC*C16	FC/MC/PC48C	0.96	0.91	1.06
L*LC*C16	FC/MC/PC48D	0.96	0.91	1.06
L*LC*C16	FC/MC/PC60D	0.96	0.93	1.04
L*LC*C16	FC/MC62D	0.98	0.95	1.04
L*LC*C16	FC/PC60C	0.96	0.93	1.04
L*LC*C16	FC64D	1.00	0.99	1.02
L*LC*C16	HD60	0.98	0.95	1.02
L*LC*C16	UC48C	0.94	0.89	1.04
L*LC*C16	UC60C	0.96	0.92	1.04
L*LC*C20	FC/MC/PC48C	0.97	0.94	1.03
L*LC*C20	FC/MC/PC48D	0.97	0.94	1.03
L*LC*C20	FC/MC/PC60D	0.96	0.93	1.02
L*LC*C20	FC/MC62D	0.98	0.95	1.02
L*LC*C20	FC/PC60C	0.96	0.93	1.02
L*LC*C20	FC64D	1.01	0.99	1.03
L*LC*C20	HD60	0.99	0.95	1.03
L*LC*C20	UC48C	0.95	0.90	1.03
L*LC*C20	UC60C	0.97	0.93	1.01
L*9C*C16	FC/MC/PC48C	0.97	0.93	1.05
L*9C*C16	FC/MC/PC48D	0.97	0.93	1.05
L*9C*C16	FC/MC/PC60D	0.96	0.93	1.04
L*9C*C16	FC/MC62D	0.98	0.94	1.04
L*9C*C16	FC/PC60C	0.96	0.93	1.04
L*9C*C16	FC64D	1.00	0.99	1.04
L*9C*C16	HD60	0.98	0.93	1.04
L*9C*C16	UC48C	0.93	0.87	1.05
L*9C*C16	UC60C	0.95	0.89	1.05
L*9C*C20	FC/MC/PC48C	0.97	0.93	1.05
L*9C*C20	FC/MC/PC48D	0.97	0.93	1.05
L*9C*C20	FC/MC/PC60D	0.96	0.93	1.04
L*9C*C20	FC/MC62D	0.98	0.95	1.06
L*9C*C20	FC/PC60C	0.96	0.93	1.04
L*9C*C20	FC64D	1.00	0.99	1.06
L*9C*C20	HD60	0.98	0.95	1.04
L*9C*C20	UC48C	0.94	0.90	1.04
L*9C*C20	UC60C	0.96	0.93	1.04
L*9C*D20	FC/MC/PC48D	0.97	0.93	1.05
L*9C*D20	FC/MC/PC60D	0.96	0.93	1.04
L*9C*D20	FC/MC62D	0.98	0.95	1.04
L*9C*D20	FC64D	1.00	0.99	1.04
L*9C*D20	HD60	0.98	0.94	1.04
L*9C*D20	UC48D	0.94	0.90	1.04
L*9C*D20	UC60D	0.96	0.92	1.04

COOLING PERFORMANCE DATA - LOW CFM 1-STAGE OPERATION																
OUTDOOR UNIT MODEL NO.		AL8B060F4C														
INDOOR COIL MODEL NO.		FC62D + MV20D														
AIR TEMP. ENTERING OUTDOOR UNIT (°F)	ID CFM	1200					1250					1300				
	ID DB (°F)	80	80	75	80	80	80	80	75	80	80	80	80	75	80	80
	ID WB (°F)	57	62	62	67	72	57	62	62	67	72	57	62	62	67	72
65	T.C.	42.3	43.2	42.1	47.3	52.4	42.7	43.2	42.6	47.6	53.0	43.2	43.3	43.0	47.9	53.5
	S.C.	40.9	35.8	28.8	28.9	25.2	41.4	36.6	29.5	29.2	25.7	41.8	37.3	30.1	29.4	26.1
	K.W.	1.95	1.97	1.96	1.93	1.88	1.95	1.96	1.96	1.93	1.87	1.96	1.95	1.95	1.92	1.87
75	T.C.	41.1	41.6	40.6	45.4	50.2	41.6	42.0	41.0	45.8	50.7	42.1	42.4	41.4	46.1	51.1
	S.C.	39.7	35.7	28.3	28.9	24.4	40.1	36.5	29.0	29.3	24.9	40.6	37.3	29.6	29.7	25.3
	K.W.	2.37	2.38	2.38	2.35	2.31	2.37	2.37	2.37	2.35	2.30	2.37	2.37	2.37	2.35	2.30
85	T.C.	39.9	40.1	39.1	43.6	48.0	40.4	40.8	39.4	44.0	48.4	41.0	41.4	39.8	44.3	48.8
	S.C.	38.4	35.6	27.8	28.9	23.6	38.9	36.5	28.4	29.4	24.0	39.4	37.2	29.0	29.9	24.5
	K.W.	2.78	2.79	2.80	2.78	2.74	2.78	2.79	2.79	2.77	2.74	2.78	2.79	2.79	2.77	2.74
95	T.C.	38.7	38.6	37.5	41.8	45.7	39.3	39.5	37.9	42.2	46.1	39.9	40.5	38.2	42.6	46.5
	S.C.	37.1	35.6	27.3	28.9	22.9	37.7	36.4	27.9	29.5	23.2	38.3	37.2	28.5	30.2	23.6
	K.W.	3.20	3.20	3.21	3.20	3.17	3.20	3.20	3.21	3.20	3.17	3.19	3.21	3.21	3.19	3.17
105	T.C.	36.1	36.2	34.9	39.0	42.7	36.7	36.9	35.3	39.4	43.1	37.2	37.7	35.6	39.7	43.4
	S.C.	35.0	34.0	26.2	27.8	21.8	35.5	34.6	26.8	28.4	22.2	35.9	35.3	27.4	28.9	22.5
	K.W.	3.78	3.79	3.79	3.77	3.74	3.78	3.79	3.78	3.76	3.74	3.77	3.79	3.78	3.76	3.74
115	T.C.	33.6	33.8	32.4	36.3	39.8	34.2	34.4	32.8	36.6	40.1	34.7	35.0	33.1	37.0	40.4
	S.C.	32.9	32.4	25.1	26.7	20.8	33.3	32.9	25.7	27.2	21.1	33.7	33.5	26.3	27.7	21.5
	K.W.	4.34	4.35	4.35	4.31	4.29	4.34	4.35	4.34	4.31	4.29	4.34	4.36	4.34	4.31	4.29
125	T.C.	31.1	31.4	29.9	33.6	36.9	31.6	31.9	30.2	33.9	37.1	32.1	32.3	30.6	34.2	37.4
	S.C.	30.8	30.9	23.9	25.6	19.7	31.1	31.2	24.6	26.1	20.1	31.4	31.6	25.2	26.6	20.4
	K.W.	4.91	4.92	4.91	4.86	4.85	4.90	4.92	4.90	4.86	4.84	4.90	4.92	4.90	4.86	4.84

NOTE: ALL CAPACITIES INCLUDE INDOOR FAN HEAT. KW VALUES ARE FOR THE SYSTEM (OUTDOOR + INDOOR).

Multipliers for determining the performance with other indoor sections.

NOTE: For dry bulb temperatures different than those listed (between 73-87 °F), sensible capacity increases by 1060 BTUH per 1000 CFM per degree above the listed temperature and decreases by 1060 BTUH per 1000 CFM per degree below the listed temperature.

LOW CFM

Air Handlers	Coils	T.C.	S.C.	KW
-	FC/MC62	1.00	1.00	1.16
AHE60D	-	0.98	0.96	1.01
AHV60D	-	0.97	0.94	1.00
MV20D	FC/MC60D	0.98	0.94	1.01
MV20D	FC/MC62D	1.00	1.00	1.00
MV20D	FC64D	1.02	0.99	1.00

Continued on next page.

Furnaces	Coils	T.C.	S.C.	KW
T*(8,L)V*C16	FC/PC60C	0.95	0.89	1.02
T*(8,L)V*C20	FC/MC/PC60D	0.96	0.91	1.02
T*(8,L)V*C20	FC/MC62D	0.95	0.91	1.03
T*(8,L)V*C20	FC/PC60C	0.96	0.91	1.02
T*(8,L)V*C20	FC64D	0.99	0.95	1.01
T*(8,L)V*C20	HD60	0.95	0.91	1.01
T*(8,L)V*C20	UC60C	0.94	0.89	1.01
T*9V*C20	FC/MC/PC60D	0.96	0.91	1.03
T*9V*C20	FC/MC62D	0.95	0.91	1.02
T*9V*C20	FC/PC60C	0.96	0.91	1.03
T*9V*C20	FC64D	0.99	0.94	1.03
T*9V*C20	HD60	0.96	0.93	1.03
T*9V*C20	UC60C	0.95	0.90	1.03
T*9V*D20	FC/MC/PC60D	0.96	0.91	1.03
T*9V*D20	FC/MC62D	0.97	0.93	1.04
T*9V*D20	FC64D	1.00	0.96	1.02
T*9V*D20	HD60	0.96	0.93	1.03
T*9V*D20	UC60D	0.95	0.91	1.03
TM8X080C16MP11	FC/MC/PC60D	0.96	0.91	1.01
TM8X080C16MP11	FC/MC62D	0.96	0.92	1.01
TM8X080C16MP11	FC/PC60C	0.95	0.90	1.01
TM8X080C16MP11	FC64D	0.99	0.95	0.99
TM8X080C16MP11	UC60C	0.94	0.89	1.01
TM8X080C16MP11	UC60D	0.94	0.89	1.01
TM8X100C16MP11	FC/MC/PC60D	0.96	0.91	1.01
TM8X100C16MP11	FC/MC62D	0.96	0.92	1.01
TM8X100C16MP11	FC/PC60C	0.95	0.90	1.01
TM8X100C16MP11	FC64D	0.99	0.95	0.99
TM8X100C16MP11	UC60C	0.94	0.89	1.01
TM8X100C16MP11	UC60D	0.94	0.89	1.01
TM8X100C20MP11	FC/MC/PC60D	0.97	0.93	1.02
TM8X100C20MP11	FC/MC62D	0.97	0.94	1.02
TM8X100C20MP11	FC/PC60C	0.97	0.92	1.02
TM8X100C20MP11	HD60	1.00	1.00	1.02
TM8X100C20MP11	UC60C	0.96	0.91	1.02
TM8X100C20MP11	UC60D	0.96	0.93	1.01
TM8X120C20MP11	FC/MC/PC60D	0.97	0.93	1.02
TM8X120C20MP11	FC/MC62D	0.97	0.94	1.02
TM8X120C20MP11	FC/PC60C	0.97	0.92	1.02
TM8X120C20MP11	HD60	1.00	1.00	1.02
TM8X120C20MP11	UC60C	0.96	0.91	1.02
TM8X120C20MP11	UC60D	0.96	0.93	1.01
TMLX080C16MP11	FC/MC/PC60D	0.96	0.91	1.01
TMLX080C16MP11	FC/MC62D	0.96	0.92	1.01
TMLX080C16MP11	FC/PC60C	0.95	0.90	1.01
TMLX080C16MP11	FC64D	0.99	0.95	0.99
TMLX080C16MP11	UC60C	0.94	0.89	1.01
TMLX080C16MP11	UC60D	0.94	0.89	1.01
TMLX100C16MP11	FC/MC/PC60D	0.96	0.91	1.01
TMLX100C16MP11	FC/MC62D	0.96	0.92	1.01
TMLX100C16MP11	FC/PC60C	0.95	0.90	1.01
TMLX100C16MP11	FC64D	0.99	0.95	0.99

Furnaces	Coils	T.C.	S.C.	KW
TMLX100C16MP11	UC60C	0.94	0.89	1.01
TMLX100C16MP11	UC60D	0.94	0.89	1.01
TMLX100C20MP11	FC/MC/PC60D	0.97	0.93	1.02
TMLX100C20MP11	FC/MC62D	0.97	0.94	1.02
TMLX100C20MP11	FC/PC60C	0.97	0.92	1.02
TMLX100C20MP11	HD60	1.00	1.00	1.02
TMLX100C20MP11	UC60C	0.96	0.91	1.02
TMLX100C20MP11	UC60D	0.96	0.93	1.01
TMLX120C20MP11	FC/MC/PC60D	0.97	0.93	1.02
TMLX120C20MP11	FC/MC62D	0.97	0.94	1.02
TMLX120C20MP11	FC/PC60C	0.97	0.92	1.02
TMLX120C20MP11	HD60	1.00	1.00	1.02
TMLX120C20MP11	UC60C	0.96	0.91	1.02
TMLX120C20MP11	UC60D	0.96	0.93	1.01
TM9E100C20MP11	FC/MC/PC60D	0.94	0.88	1.00
TM9E100C20MP11	FC/MC62D	0.95	0.90	1.01
TM9E100C20MP11	FC64D	0.98	0.93	0.99
TM9E100C20MP11	HD60	1.00	1.00	1.04
TM9E100C20MP11	UC60D	0.93	0.87	1.01
TM9E120D20MP11	FC/MC/PC60D	0.95	0.89	0.99
TM9E120D20MP11	FC/MC62D	0.94	0.89	1.00
TM9E120D20MP11	FC64D	0.97	0.92	0.99
TM9E120D20MP11	HD60	1.00	1.00	1.02
TM9E120D20MP11	UC60D	0.95	0.89	1.01
TM9X100C20MP11	FC/MC/PC60D	0.94	0.88	1.00
TM9X100C20MP11	FC/MC62D	0.95	0.90	1.01
TM9X100C20MP11	FC64D	0.98	0.93	0.99
TM9X100C20MP11	HD60	1.00	1.00	1.04
TM9X100C20MP11	UC60D	0.93	0.87	1.01
TM9X120D20MP11	FC/MC/PC60D	0.95	0.89	0.99
TM9X120D20MP11	FC/MC62D	0.94	0.89	1.00
TM9X120D20MP11	FC64D	0.97	0.92	0.99
TM9X120D20MP11	HD60	1.00	1.00	1.02
TM9X120D20MP11	UC60D	0.95	0.89	1.01
L*LC*C16	FC/PC60C	0.95	0.89	1.02
L*LC*C20	FC/MC/PC60D	0.96	0.91	1.02
L*LC*C20	FC/MC62D	0.95	0.91	1.03
L*LC*C20	FC/PC60C	0.96	0.91	1.02
L*LC*C20	FC64D	0.99	0.95	1.01
L*LC*C20	HD60	0.95	0.91	1.01
L*LC*C20	UC60C	0.94	0.89	1.01
L*9C*C20	FC/MC/PC60D	0.96	0.91	1.03
L*9C*C20	FC/MC62D	0.95	0.91	1.02
L*9C*C20	FC/PC60C	0.96	0.91	1.03
L*9C*C20	FC64D	0.99	0.94	1.03
L*9C*C20	HD60	0.96	0.93	1.03
L*9C*C20	UC60C	0.95	0.90	1.03
L*9C*D20	FC/MC/PC60D	0.96	0.91	1.03
L*9C*D20	FC/MC62D	0.97	0.93	1.04
L*9C*D20	FC64D	1.00	0.96	1.02
L*9C*D20	HD60	0.96	0.93	1.03
L*9C*D20	UC60D	0.95	0.91	1.03

COOLING PERFORMANCE DATA - HIGH CFM 2-STAGE OPERATION																
OUTDOOR UNIT MODEL NO.		AL8B060F4C														
INDOOR COIL MODEL NO.		FC62D + MV20D														
AIR TEMP. ENTERING OUTDOOR UNIT (°F)	ID CFM	1775					1875					1975				
	ID DB (°F)	80	80	75	80	80	80	80	75	80	80	80	80	75	80	80
	ID WB (°F)	57	62	62	67	72	57	62	62	67	72	57	62	62	67	72
65	T.C.	59.6	62.4	59.4	63.7	70.0	60.7	62.5	60.2	65.3	70.5	61.7	62.5	61.0	67.0	70.9
	S.C.	57.8	55.2	42.4	39.9	34.2	58.7	55.9	43.5	42.8	34.6	59.5	56.6	44.7	45.7	35.0
	K.W.	3.20	3.25	3.22	3.32	3.35	3.25	3.30	3.28	3.35	3.40	3.32	3.36	3.35	3.40	3.46
75	T.C.	57.8	59.4	56.9	61.6	67.5	58.8	59.6	57.6	62.9	67.8	59.7	59.8	58.3	64.2	68.1
	S.C.	56.0	53.1	41.2	40.0	33.3	56.8	54.0	42.2	42.3	33.7	57.5	54.8	43.2	44.5	34.0
	K.W.	3.69	3.74	3.71	3.81	3.84	3.75	3.79	3.77	3.85	3.89	3.81	3.85	3.84	3.90	3.95
85	T.C.	56.0	56.4	54.5	59.5	64.9	56.9	56.7	55.0	60.4	65.2	57.7	57.0	55.6	61.4	65.4
	S.C.	54.1	51.1	39.9	40.1	32.5	54.8	52.0	40.9	41.7	32.8	55.5	53.0	41.8	43.3	33.1
	K.W.	4.18	4.22	4.20	4.30	4.34	4.24	4.28	4.26	4.34	4.39	4.31	4.34	4.32	4.39	4.45
95	T.C.	54.2	53.4	52.0	57.4	62.3	55.0	53.9	52.4	58.0	62.5	55.7	54.3	52.9	58.6	62.6
	S.C.	52.2	49.0	38.7	40.2	31.7	52.9	50.1	39.6	41.2	31.9	53.5	51.2	40.4	42.2	32.2
	K.W.	4.67	4.71	4.69	4.79	4.84	4.73	4.76	4.74	4.83	4.89	4.80	4.83	4.80	4.89	4.95
105	T.C.	50.5	50.4	49.1	53.9	58.4	51.4	51.0	49.6	54.4	58.7	52.3	51.5	50.0	54.9	58.9
	S.C.	49.0	47.3	38.0	38.7	30.1	49.8	48.2	38.9	39.6	30.4	50.6	49.2	39.8	40.5	30.7
	K.W.	5.40	5.42	5.40	5.49	5.55	5.46	5.48	5.45	5.54	5.60	5.53	5.54	5.51	5.59	5.66
115	T.C.	46.9	47.5	46.3	50.5	54.7	48.0	48.1	46.8	50.9	55.0	49.0	48.7	47.2	51.3	55.3
	S.C.	45.9	45.6	37.4	37.2	28.6	46.8	46.5	38.3	38.1	29.0	47.7	47.2	39.1	38.9	29.3
	K.W.	6.11	6.12	6.08	6.17	6.24	6.17	6.17	6.13	6.22	6.29	6.24	6.24	6.19	6.28	6.35
125	T.C.	43.3	44.6	43.5	47.2	50.9	44.5	45.3	44.0	47.5	51.3	45.8	45.9	44.4	47.7	51.6
	S.C.	42.7	44.0	36.7	35.8	27.0	43.8	44.7	37.7	36.5	27.5	44.8	45.3	38.5	37.3	27.9
	K.W.	6.82	6.81	6.76	6.86	6.94	6.88	6.86	6.81	6.91	6.99	6.94	6.93	6.87	6.97	7.05

NOTE: ALL CAPACITIES INCLUDE INDOOR FAN HEAT. KW VALUES ARE FOR THE SYSTEM (OUTDOOR + INDOOR).

Multipliers for determining the performance with other indoor sections.

NOTE: For dry bulb temperatures different than those listed (between 73-87 °F), sensible capacity increases by 1060 BTUH per 1000 CFM per degree above the listed temperature and decreases by 1060 BTUH per 1000 CFM per degree below the listed temperature.

HIGH CFM

Air Handlers	Coils	T.C.	S.C.	KW
-	FC/MC62	0.97	0.96	1.04
AHE60D	-	0.99	0.99	1.01
AHV60D	-	0.97	0.94	0.99
MV20D	FC/MC60D	0.98	0.96	1.00
MV20D	FC/MC62D	1.00	1.00	1.00
MV20D	FC64D	1.01	1.01	1.03

Continued on next page.

Furnaces	Coils	T.C.	S.C.	KW
T*(8,L)V*C16	FC/PC60C	0.95	0.90	1.01
T*(8,L)V*C20	FC/MC/PC60D	0.96	0.90	1.00
T*(8,L)V*C20	FC/MC62D	0.97	0.93	1.01
T*(8,L)V*C20	FC/PC60C	0.96	0.90	1.00
T*(8,L)V*C20	FC64D	1.01	1.01	1.03
T*(8,L)V*C20	HD60	0.97	0.92	0.99
T*(8,L)V*C20	UC60C	0.96	0.91	1.00
T*9V*C20	FC/MC/PC60D	0.96	0.91	1.02
T*9V*C20	FC/MC62D	0.97	0.93	1.01
T*9V*C20	FC/PC60C	0.96	0.91	1.02
T*9V*C20	FC64D	0.99	0.96	1.01
T*9V*C20	HD60	0.96	0.93	1.00
T*9V*C20	UC60C	0.96	0.91	1.02
T*9V*D20	FC/MC/PC60D	0.96	0.90	1.00
T*9V*D20	FC/MC62D	0.97	0.93	1.01
T*9V*D20	FC64D	0.99	0.95	1.01
T*9V*D20	HD60	0.97	0.92	1.01
T*9V*D20	UC60D	0.95	0.90	1.01
TM8X080C16MP11	FC/MC/PC60D	0.95	0.89	1.01
TM8X080C16MP11	FC/MC62D	0.96	0.91	1.00
TM8X080C16MP11	FC/PC60C	0.94	0.88	1.00
TM8X080C16MP11	FC64D	0.98	0.94	1.00
TM8X080C16MP11	UC60C	0.94	0.88	1.00
TM8X080C16MP11	UC60D	0.94	0.88	1.00
TM8X100C16MP11	FC/MC/PC60D	0.95	0.89	1.01
TM8X100C16MP11	FC/MC62D	0.96	0.91	1.00
TM8X100C16MP11	FC/PC60C	0.94	0.88	1.00
TM8X100C16MP11	FC64D	0.98	0.94	1.00
TM8X100C16MP11	UC60C	0.94	0.88	1.00
TM8X100C16MP11	UC60D	0.94	0.88	1.00
TM8X100C20MP11	FC/MC/PC60D	0.96	0.90	1.00
TM8X100C20MP11	FC/MC62D	0.97	0.92	1.01
TM8X100C20MP11	FC/PC60C	0.95	0.89	0.99
TM8X100C20MP11	HD60	0.97	0.95	0.97
TM8X100C20MP11	UC60C	0.95	0.89	0.99
TM8X100C20MP11	UC60D	0.95	0.90	0.99
TM8X120C20MP11	FC/MC/PC60D	0.96	0.90	1.00
TM8X120C20MP11	FC/MC62D	0.97	0.92	1.01
TM8X120C20MP11	FC/PC60C	0.95	0.89	0.99
TM8X120C20MP11	HD60	0.97	0.95	0.97
TM8X120C20MP11	UC60C	0.95	0.89	0.99
TM8X120C20MP11	UC60D	0.95	0.90	0.99
TMLX080C16MP11	FC/MC/PC60D	0.95	0.89	1.01
TMLX080C16MP11	FC/MC62D	0.96	0.91	1.00
TMLX080C16MP11	FC/PC60C	0.94	0.88	1.00
TMLX080C16MP11	FC64D	0.98	0.94	1.00
TMLX080C16MP11	UC60C	0.94	0.88	1.00
TMLX080C16MP11	UC60D	0.94	0.88	1.00
TMLX100C16MP11	FC/MC/PC60D	0.95	0.89	1.01
TMLX100C16MP11	FC/MC62D	0.96	0.91	1.00
TMLX100C16MP11	FC/PC60C	0.94	0.88	1.00
TMLX100C16MP11	FC64D	0.98	0.94	1.00

Furnaces	Coils	T.C.	S.C.	KW
TMLX100C16MP11	UC60C	0.94	0.88	1.00
TMLX100C16MP11	UC60D	0.94	0.88	1.00
TMLX100C20MP11	FC/MC/PC60D	0.96	0.90	1.00
TMLX100C20MP11	FC/MC62D	0.97	0.92	1.01
TMLX100C20MP11	FC/PC60C	0.95	0.89	0.99
TMLX100C20MP11	HD60	0.97	0.95	0.97
TMLX100C20MP11	UC60C	0.95	0.89	0.99
TMLX100C20MP11	UC60D	0.95	0.90	0.99
TMLX120C20MP11	FC/MC/PC60D	0.96	0.90	1.00
TMLX120C20MP11	FC/MC62D	0.97	0.92	1.01
TMLX120C20MP11	FC/PC60C	0.95	0.89	0.99
TMLX120C20MP11	HD60	0.97	0.95	0.97
TMLX120C20MP11	UC60C	0.95	0.89	0.99
TMLX120C20MP11	UC60D	0.95	0.90	0.99
TM9E100C20MP11	FC/MC/PC60D	0.94	0.88	1.00
TM9E100C20MP11	FC/MC62D	0.96	0.91	1.00
TM9E100C20MP11	FC64D	0.98	0.94	1.00
TM9E100C20MP11	HD60	0.97	0.95	0.97
TM9E100C20MP11	UC60D	0.94	0.88	1.00
TM9E120D20MP11	FC/MC/PC60D	0.95	0.89	0.99
TM9E120D20MP11	FC/MC62D	0.96	0.91	1.00
TM9E120D20MP11	FC64D	0.98	0.93	1.00
TM9E120D20MP11	HD60	0.97	0.94	0.99
TM9E120D20MP11	UC60D	0.94	0.88	1.00
TM9X100C20MP11	FC/MC/PC60D	0.94	0.88	1.00
TM9X100C20MP11	FC/MC62D	0.96	0.91	1.00
TM9X100C20MP11	FC64D	0.98	0.94	1.00
TM9X100C20MP11	HD60	0.97	0.95	0.97
TM9X100C20MP11	UC60D	0.94	0.88	1.00
TM9X120D20MP11	FC/MC/PC60D	0.95	0.89	0.99
TM9X120D20MP11	FC/MC62D	0.96	0.91	1.00
TM9X120D20MP11	FC64D	0.98	0.93	1.00
TM9X120D20MP11	HD60	0.97	0.94	0.99
TM9X120D20MP11	UC60D	0.94	0.88	1.00
L*LC*C16	FC/PC60C	0.95	0.90	1.01
L*LC*C20	FC/MC/PC60D	0.96	0.90	1.00
L*LC*C20	FC/MC62D	0.97	0.93	1.01
L*LC*C20	FC/PC60C	0.96	0.90	1.00
L*LC*C20	FC64D	1.01	1.01	1.03
L*LC*C20	HD60	0.97	0.92	0.99
L*LC*C20	UC60C	0.96	0.91	1.00
L*9C*C20	FC/MC/PC60D	0.96	0.91	1.02
L*9C*C20	FC/MC62D	0.97	0.93	1.01
L*9C*C20	FC/PC60C	0.96	0.91	1.02
L*9C*C20	FC64D	0.99	0.96	1.01
L*9C*C20	HD60	0.96	0.93	1.00
L*9C*C20	UC60C	0.96	0.91	1.02
L*9C*D20	FC/MC/PC60D	0.96	0.90	1.00
L*9C*D20	FC/MC62D	0.97	0.93	1.01
L*9C*D20	FC64D	0.99	0.95	1.01
L*9C*D20	HD60	0.97	0.92	1.01
L*9C*D20	UC60D	0.95	0.90	1.01

NOTES